

Daniel™ Series 1200

Liquid Turbine Flow Meter



Series 1200 Liquid Turbine Flow Meter

Durability for Sustained Performance

Achieving highly accurate volumetric flow measurement of liquid hydrocarbons requires technology that ensures linearity and repeatability. Load rack and marketing terminal operators worldwide rely on the Daniel Series 1200 Liquid Turbine Meter for reliable measurement during custody transfer and batch or in-line blending operations. Designed for demanding applications, the field-proven meter now features potted electronics along with rugged internals to provide steady, long-term performance.

The meter's simple configuration and self-cleaning flow-through bearing design enable higher flow rates and an extended flow range, particularly on light hydrocarbons and light crude products. In addition, all DN40 (1.5-in) meters and larger can be equipped with an optional integral flow conditioning plate that often eliminates the need for traditional flow conditioning methods. The plate allows for vertical installation when space is at a premium. An expanding hanger suspension system and positive rotor centering further ensure the meter is equally effective in a vertical orientation.

Another key advantage is the meter's local mounted enclosure (LME) that can be configured with one or two pickoff coils and a standard dual-channel preamplifier. The combination of these components ensures total pulse integrity, virtually eliminating the potential for missing or double-counted pulses.

API Compliant

The Series 1200 Liquid Turbine Flow Meter is specifically designed for pipeline operation and for use within the guidelines of the API Manual of Petroleum Measurement Standards (MPMS), Chapter 5.3 (Measurement of Liquid Hydrocarbons by Turbine Meter) and the calibration procedures of MPMS, Chapter 4 (Proving Systems).

Typical Applications

- Refined product loading / unloading
- Batch / in-line blending operations

Features and Benefits

- Pulse output linear with flow rate and 10:1 rangeability (turndown) ensure custody transfer and fiscal measurement accuracy
- High-frequency pulse resolution enables measurement of minute increments of flow rate for greater accountability
- Stainless steel internal assembly ensures maximum volume throughput and minimum pressure drop
- Stainless steel ball or tungsten journal carbide bearings guarantee durability and longevity with minimal maintenance required
- Local mounted enclosure (LME) configured with one or two pickoffs and a standard dual-channel preamplifier for total pulse integrity
- Electronics designed for easy access to pickoffs and preamplifier to simplify service
- LME aluminum or stainless steel (optional) housing is explosion and weather proof for safe operation within refineries and harsh environments

A Range of Available Options

- DN25 to DN100 (1-in to 4-in) line sizes
- Stainless or carbon steel meter body
- NACE MR0175-compliant construction
- Single or dual LME in stainless steel



Figure 1: Daniel 1200 Liquid Turbine Flow Meter

Standard Specifications⁽¹⁾

Process Parameters

Table 1: Process Temperature Range⁽¹⁾

	Carbon Steel	304/316 Stainless Steel
Standard	-29°C to +60°C (-20°F to +140°F)	-40°C to +60°C (-40°F to +140°F)

Table 2: Linearity

Size		Standard Linearity	Premium Linearity	Repeatability
DN	Inches			
25 to 50	1 to 2	±0.25%	±0.15%	±0.02%
80 to 100	3 to 4	±0.15%	NA	±0.02%

Table 3A: Flange Pressure Ratings (Metric Units)

PN	Pressure Rating, barg @ 38°C	
	Carbon Steel	304/316 Stainless Steel
20	19.7	19.0
50	51.0	49.6

Table 3B: Flange Pressure Ratings (US Customary Units)

ANSI	Pressure Rating, psig @ 100°F	
	Carbon Steel	304/316 Stainless Steel
150	285	275
300	740	720

Safety and Compliance

Electrical

- UL / c-UL Class I, Division 1, Groups B, C and D
- ATEX: Ex d IIC T6 Gb
- IECEx: Ex d IIC T6 Gb
- INMETRO: BR- Ex d IIC T6 Gb

Environmental

- Aluminum: NEMA 4 (IEC IP66)
- Stainless Steel: NEMA 4X (IEC IP66)

Metrology

- NMi TC7573, Revision 3
- NTEP, CC: 90-118
- Measurement Canada, AV-2264

(1) Remote Mounted Enclosure (RME) is required for process or ambient temperatures > +60°C (+140°F).

Electrical

Preamplifier

The local mounted enclosure (LME) on the Daniel Series 1200 Liquid Turbine Meter contains a standard dual-channel preamplifier and two inductive pickoff coils. These coils have the sensitivity to provide accurate detection of rotor travel and have output with electrical characteristics of high impedance and low voltage. Noise-free transmission of the flow signals requires the opposite: low impedance and high voltage. This is the function of the signal preamplifier. Located within 5 meters (16.4 feet) of the pickoff coil, turbine meter preamplifiers shape and condition the pickoff output signal, rendering it suitable for transmission over distances of up to 914 meters (3,000 feet).

Standard Model

The Model 2818 Dual Channel Preamplifier is the standard Daniel offering for the Series 1200 meter. The signals from two inductive pickoff coils, positioned 90° electrically out of phase, are strengthened and conditioned by a single preamplifier. Fully potted in Delrin® resin, the Model 2818 preamplifier has three possible outputs: powered pulse, variable voltage and open collector.

Electrical Performance

Pickoff Specifications

- Type: 2-wire reluctance
- Resistance: 600 - 900 ohms
- Inductance: 250mH max
- Output: Sinusoidal 40mV p-p minimum @minimum flow with preamplifier load
- Optional: 2 pickoff coils (single or dual LME) or 4 pickoff coils (dual LME required)

Table 4: Standard Preamplifier

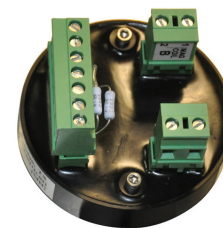

DESCRIPTION	Dual Channel
MODEL	2818
Part #	1-504-05-550
INPUTS	
# of Inputs (Pickoffs):	1 or 2
Supply Voltage:	10 to 30 VDC
Sensor Type:	Reluctance
Signal:	Sine Wave
Current:	10 to 30 VDC @ 40 mA _{p-p}
Preamplifier Sensitivity:	40 mV _{pp}
Frequency Response:	0 to 5 kHz
OUTPUTS (POWERED PULSE)	
Type:	Square Wave
Frequency Range:	≤ 0 to 5 kHz
Amplitude:	0 to 5 V
Impedance:	1000 Ohm, 20 mA max
CONSTRUCTION	Delrin Housing Solid Epoxy Encapsulation
TEMPERATURE RANGE	-40°C to +85°C (-40°F to +185°F)
CUSTOMER CONNECTION	
Terminal Block 1 (TB1):	(1) +10 to 30 VDC (2) Common (3) Common (4) Channel A Output (5) Channel B Output (6) TTL Out A (7) TTL Out B
PICKOFFS	
Channel A (TB2):	(1) White (2) Red
Channel B (TB3):	(1) White (2) Red

Standard Flow Range and Adjustments

The flow rate must fall within the minimum and maximum linear flow rate to meet the standard and premium linearity specification. Tables 8A, 8B and 8C represent the effect of specific gravity on the linear flow range.

Table 5: Linear Flow Range										
Nominal Size		BBL/HR			M ³ /HR			USG/PM		
		Standard Flow Range		Extended Maximum Flow Range*	Standard Flow Range		Extended Maximum Flow Range*	Standard Flow Range		Extended Maximum Flow Range*
DN	Inches	Minimum	Maximum		Minimum	Maximum		Minimum	Maximum	
25	1	8.6	86	99	1.4	14	16	6	60	69
40	1.5	19	186	214	3.0	30	34	13	130	150
50	2	31	314	361	5.0	50	58	22	220	253
80	3	93	929	1,068	15	148	170	65	650	748
100	4	143	1,429	1,785	23	227	284	100	1,000	1,250

* Note: Extended maximum flow range with 20% duty cycle not to exceed 2 hours per day

Table 6: Nominal K-Factor				
Nominal Size		K-Factor*		
DN	Inches	Pulses/BBL	Pulses/M ³	Pulses/USG
25	1	33,600	211,338	800
40	1.5	16,800	105,669	400
50	2	7,560	47,551	180
80	3	2,184	13,737	52
100	4	966	6,076	23

* Note: K-Factors for individual rotors vary. An acceptable rotor can be nominal ±15%.

Table 7A: Flow Range Adjustments for Specific Gravity = 0.7 to 1 (Blade Type Internals Only)							
Nominal Size		Minimum Linear Flow Rate			Maximum Linear Flow Rate		
DN	Inches	BBL/HR	M ³ /HR	USGPM	BBL/HR	M ³ /HR	USG/PM
25	1	8.6	1.4	6.0	86	14	60
40	1.5	19	3.0	13	186	30	130
50	2	31	5.0	22	314	50	220
80	3	93	15	65	929	148	650
100	4	143	23	100	1,429	227	1,000

Table 7B: Flow Range Adjustments for Specific Gravity = 0.6 (Blade Type Internals Only)							
Nominal Size		Minimum Linear Flow Rate			Maximum Linear Flow Rate		
DN	Inches	BBL/HR	M ³ /HR	USGPM	BBL/HR	M ³ /HR	USG/PM
25	1	14	2.3	10	99	16	69
40	1.5	31	5.0	22	214	34	150
50	2	53	8.4	37	361	58	253
80	3	156	25	109	1,071	170	750
100	4	239	38	167	1,786	284	1,250

Table 7C: Flow Range Adjustments for Specific Gravity = 0.5 (Blade Type Internals Only)							
Nominal Size		Minimum Linear Flow Rate			Maximum Linear Flow Rate		
DN	Inches	BBL/HR	M ³ /HR	USGPM	BBL/HR	M ³ /HR	USG/PM
25	1	20	3.2	14	99	16	69
40	1.5	44	7.0	31	214	34	150
50	2	74	12	52	361	58	253
80	3	219	35	153	1,071	170	750
100	4	336	53	235	1,786	284	1,250

Pressure Drop

The pressure drop characteristics on water for the Series 1200 Liquid Turbine Meter by line size.

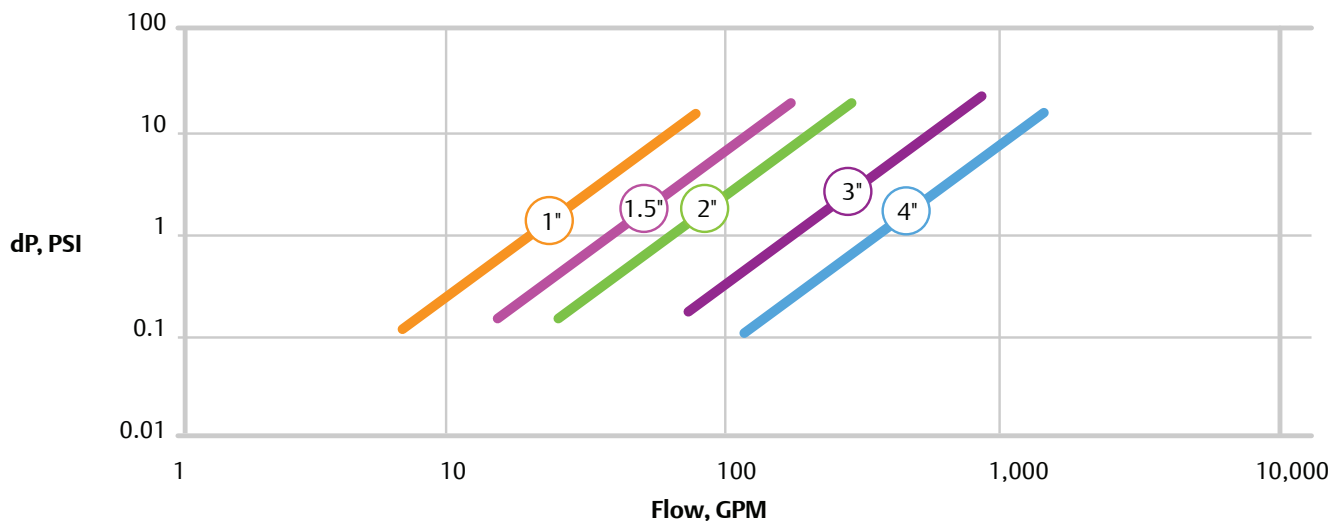

Figure 2: Pressure Drop Chart

Table 8A: Series 1200 Pressure Drop (Metric Units)											
Flow Range		No Conditioner		Integral Flow Conditioner							
		DN25		DN40		DN50		DN80		DN100	
		M ³ /H	mBar	M ³ /H	mBar	M ³ /H	mBar	M ³ /H	mBar	M ³ /H	mBar
Standard Flow Range	Minimum	1.36	7.7	2.95	9.4	5	9.5	14.8	11.0	22.7	6.6
	Maximum	13.6	765	29.5	938	50	952	148	1,096	227	655
Extended Maximum		16	11,007	34	1,248	58	1,255	170	1,462	284	1,020

Table 8B: Series 1200 Pressure Drop (US Customary Units)											
Flow Range		No Conditioner		Integral Flow Conditioner							
		1-in		1.5-in		2-in		3-in		4-in	
		GPM	dP	GPM	dP	GPM	dP	GPM	dP	GPM	dP
Standard Flow Range	Minimum	6	0.111	13	0.136	22	0.138	65	0.159	100	0.095
	Maximum	60	11.1	130	13.6	220	13.8	650	15.9	1,000	9.5
Extended Maximum		69	14.6	150	18.1	253	18.2	750	21.2	1,250	14.8

Product Diagrams

Local Mounted Enclosure (LME)

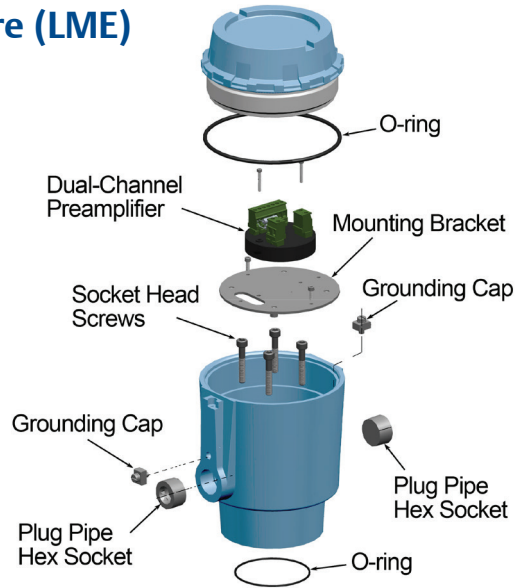

Figure 3: Local Mounted Enclosure (LME) with Standard Dual-Channel Preamp

Internals with Stainless Steel Bearings

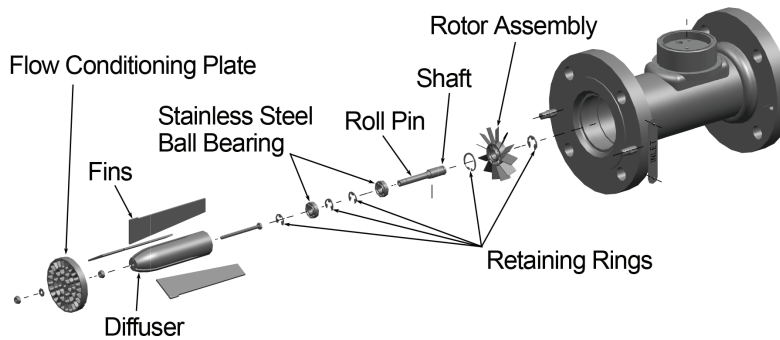

Figure 4: Internal Assembly for a Nominal Pipe Size DN80 to DN100 (3-in to 4-in) Liquid Turbine Meter

Internals with Tungsten Carbide Bearings

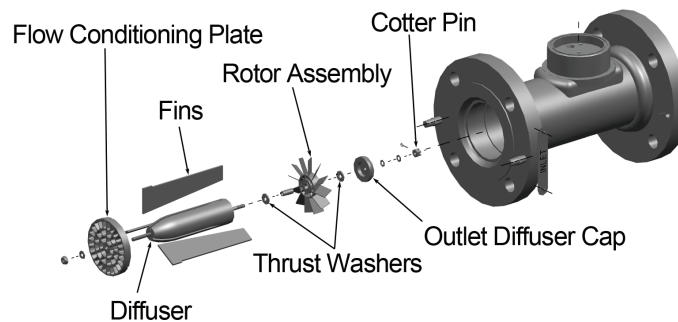

Figure 5: Internal Assembly for a Nominal Pipe Size DN80 to DN100 (3-in to 4-in) Liquid Turbine Meter

Materials of Construction

Table 9A: Meter with Stainless Steel Bearings (DN25 to DN100 / 1-in to 4-in)

Description	Standard	NACE MR0175:2003 Compliant
Meter Body and Flanges		
DN25 to DN40 (1-in to 1.5-in)	304SS Only	304SS Only
DN50 to DN100 (2-in to 4-in)	Carbon Steel or 304SS	Carbon Steel or 304SS
Local Mounted Enclosure (LME)	Aluminum / 316SS	Aluminum / 316SS
Rotor Hub/ Rotor Blades		
DN25 to DN40 (1-in to 1.5-in)	17-4PH	430SS
DN50 to DN100 (2-in to 4-in)	Aluminum 6061-T6 / 430SS	Aluminum 6061-T6 / 430SS
Retaining Ring		
DN25 to DN40 (1-in to 1.5-in)	302SS	302SS
DN50 to DN100 (2-in to 4-in)		
Bearing Spacer		
DN25 to DN50 (1-in to 2-in)	302SS	302SS
DN80 to DN100 (3-in to 4-in)		
Shaft		
DN25 (1-in)	303SS	303SS
DN40 to DN50 (1.5-in to 2-in)	304SS	304SS
DN80 (3-in)	Aluminum 6061-T6	Aluminum 6061-T6
DN100 (4-in)	Aluminum 2011-T3	Aluminum 2011-T3
Bearing Set	Stainless Steel	Stainless Steel
Suspension Blade		
DN25 (1-in)	304SS	304SS
DN40 to 100 (1.5-in to 4-in)	Aluminum 2024-T3	Aluminum 2024-T3
Suspension Diffuser		
DN25 (1-in)	316SS	316SS
DN40 to DN100 (1.5-in to 4-in)	Aluminum 6061-T6	Aluminum 6061-T6
Downstream Cone		
DN25 (1-in)		
DN40 to DN100 (1.5-in to 4-in)	303SS	303SS
Sleeve		
DN25 (1-in)	304SS	304SS
DN40 to DN100 (1.5-in to 4-in)		
Flow Conditioning Plate		
DN25 (1-in)		
DN40 to DN50 (1.5-in to 2-in)	Delrin	NA
DN80 to DN100 (3-in to 4-in)	Delrin / Aluminum	Aluminum
Table 9B: Meter with Tungsten Carbide Bearings (DN 80 to 100 / 3-in to 4-in)		
Meter Body and Flanges	Carbon Steel or 304SS	Carbon Steel or 304SS
Local Mounted Enclosure (LME)	316SS	316SS
Rotor Hub / Rotor Blades	Aluminum 6061-T6 / 430SS	Aluminum 6061-T6 / 430SS
Shaft	303SS	303SS
Bearing Set	Tungsten Carbide	Tungsten Carbide
Suspension Blade	Aluminum 2024-T3	Aluminum 2024-T3
Suspension Diffuser	Aluminum 6061-T6	Aluminum 6061-T6
Diffuser Washer	Aluminum 6061-T6	Aluminum 6061-T6
Flow Conditioning Plate	Delrin / Aluminum	Aluminum

Weights and Dimensions

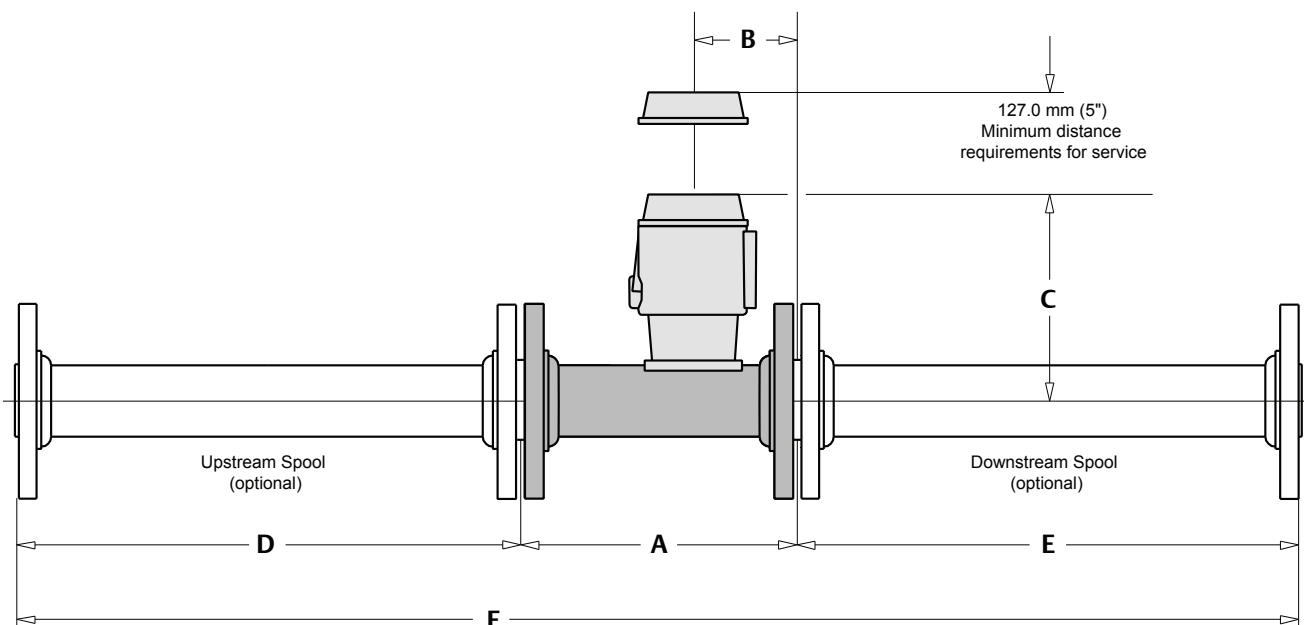

Table 10: Dimensional Data for Daniel Series 1200 Liquid Turbine Flow Meter and Flow Straightening Sections

Nominal Size		A		B		C		D		E		F	
DN	Inches	mm	Inches	mm	Inches	mm	Inches	mm	Inches	mm	Inches	mm	Inches
25	1	203	8	102	4	259	10	508	20	127	5	841	33
40	1.5	229	9	114	4.5	269	11	191	8	191	8	613	24
50	2	229	9	114	4.5	269	11	254	10	254	10	740	29
80	3	254	10	127	5	279	11	381	15	381	15	1,022	40
100	4	305	12	152	6	297	12	508	20	508	20	1,324	52

Table 11: Shipping Weight⁽¹⁾

Nominal Size		ANSI 150		ANSI 300	
DN	Inches	kg	lbs	kg	lbs
25	1	10.5	23	10.5	23
40	1.5	11.8	26	14.6	32
50	2	13.7	30	17.5	32
80	3	19.1	42	23.2	51
100	4	25.9	57	33.6	74

(1) Weight based on Turbine Meter only. For single Stainless Steel LME add 3.75 Kg (8.3 lb). For double LME's, add 7.5 Kg (16.6 lb).

Emerson Automation Solutions

Daniel Measurement and Control, Inc.
North America / Latin America:
Headquarters
USA - Houston, Texas
T +1.713.467.6000
USA Toll Free 1.888.FLOW.001

Middle East, Africa: Dubai, UAE
T +971.4.811.8100
Asia Pacific: Singapore
T +65.6777.8211

www.Emerson.com/Daniel

©2019 Daniel Measurement and Control, Inc. All Rights Reserved. Unauthorized duplication in whole or in part is prohibited. Printed in the USA. DAN-LIQ-DS-1200TM-1219

The Emerson logo is a trademark and service mark of Emerson Electric Co. Daniel Measurement and Control, Inc. ("Daniel") is an Emerson Automation Solutions business unit and a subsidiary of Daniel Industries, Inc. The Daniel name and logo are trademarks of Daniel Industries, Inc. All other trademarks are the property of their respective companies.

DANIEL™

