

Daniel™ Series 700 - Model V788

Digital Control Valve

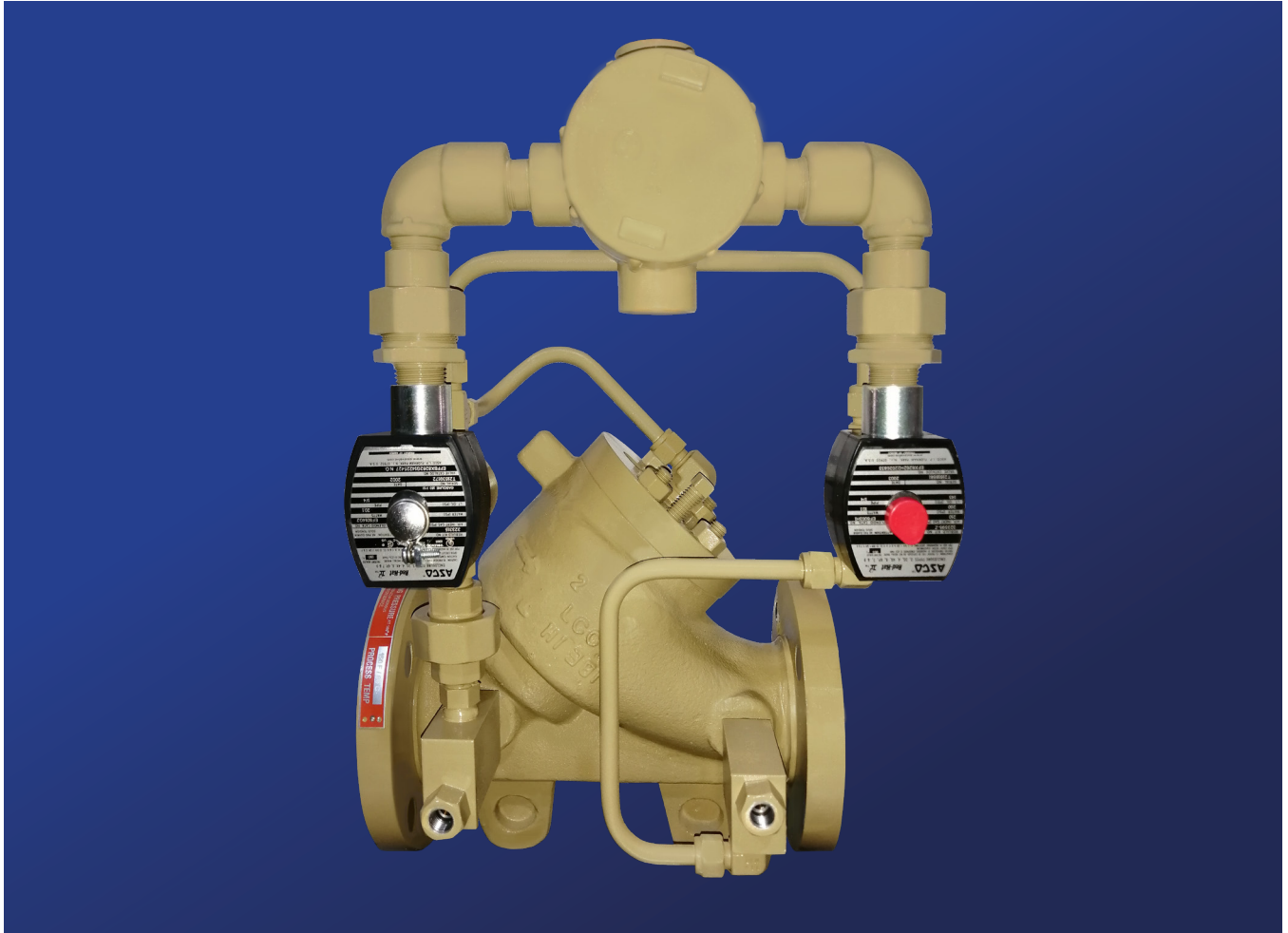

Daniel 788 Digital Control Valve

Overview

The Daniel 788 Digital Control Valve is designed to provide precise flow rate control and batch delivery of fluid products when used with an electronic batch control device (preset).

The Daniel 788 Digital Control Valve is automatically controlled by the preset for low flow start-up, high flow rate control, low flow shutdown, and final shut off. This valve also provides for maximum flowmeter accuracy by maintaining a constant flow rate with varying line pressures. The Daniel 788 Digital Control Valve features an external pilot control loop that consists of a normally open solenoid pilot, a normally closed solenoid pilot, strainer and opening/closing speed controls.

Applications

The Daniel 788 Digital Control Valve can be used in any application requiring precise flow rate control with batch capability when used with an electronic preset capable of digital valve control including loading and off-loading (truck, railcar, ship, barge, etc).

Features and Benefits

- Precise flow rate and batch control
- Modular construction – All internal parts including seat and seat ring may be removed as a cartridge assembly without the need to remove the valve body from the system piping
- No diaphragms or stuffing boxes
- 45° body design assures high capacity and low pressure drop
- Positive (bubble tight to Class VI) shut-off
- Linear control characteristics with uniform response speed
- Fail-safe closure on loss of power
- Aggressive Products (AP) Option with Teflon® elastomers



Figure 1: Daniel™ 788 Digital Liquid Control Valve

Standard Specifications

Please consult Daniel if your requirements are outside the specifications noted below. Other product and material offerings may be available depending on the application.

Flange Connections / Ratings (ANSI)

Valve size: 2" to 8"

Maximum working pressure at 38 °C

ANSI 150: 285 psi (1,964 kPa)

ANSI 300: 740 psi (5,099 kPa)

Temperature Range: -20°F to 150 °F (-29°C to 66°C)
Optional 250°F (121°C)

Flange Connections / Ratings (DIN)

Valve size: DN50 - DN200

Maximum working pressure at 38 °C

DIN PN16 MWP: 16 bar

DIN PN25 MWP: 25 bar

DIN PN40 MWP: 40 bar

DIN PN64 MWP: 51 bar

Materials of Construction

Main Valve Body: Steel - ASTM-A352-GR-LCC

Main Valve Cylinder: 2" - 4" Stainless Steel Heat Treated 17-4 pH
6" - 8" Carbon Steel, Nickel Coated

Main Valve Piston: Stainless Steel

Seat Ring: Stainless Steel
8" Carbon Steel, Nickel Coated

O-Rings: Viton® (Standard)
Available in Neoprene, EPR, Kalrez®,
Teflon® ("AP" Valves) (Optional)

Other Internal Parts: Stainless Steel

Pilot Valve / Strainer /

Needle Valve Trim: Stainless Steel

Pilot O-Rings: Viton® (Standard)
Available in Neoprene, EPR, Kalrez®,
Teflon® ("AP" Valves) (Optional)

Tubing and Fittings: Stainless Steel

Valve Capacity

Table 1: Valve Capacity					
Valve Size	2"	3"	4"	6"	8"
Cv (GPM)	86	186	309	688	1,296

Documentation and Approvals

- UL and CSA Listed
- Class I - Groups C and D
- Class II - Groups E, F and G
- Explosion Proof NEMA Types 7C, 7D, 9E, 9F, 9G and waterproof NEMA Type 4
- CE (ATEX, PED [or SEP] and EMR)
- ATEX II 2G/D EEx d IIC T6-T4

Maximum Operating Pressure Differential (MOPD) Across Pilots

150 ANSI Standard

- 150 psid (1,035 kPa)
- 285 psid (1,967 kPa) (optional)

300 ANSI Standard

- 740 psid (5,106 kPa)

Standard Equipment

- Pre-wired solenoids (optional for CE execution)
- Opening and closing speed controls
- Self-cleaning strainer (pilot inlet)
- Stainless steel solenoid pilots
- Stainless Steel tubings and fittings

Optional Equipment

- Pre-wiring for valves with CE solenoids
- Manual override
- Valve position indicator
- Thermal relief

Aggressive Products Option

The use of aggressive additives or oxygenates call for the Aggressive Products, or AP option. The AP option valve cylinder incorporates cup-seals (Teflon® Bal Seals) and an O-ring made from appropriate materials for such challenging conditions. Materials for pilots such as low swell nitrile (main valve static O-rings) and Kalrez® or Teflon® are available.

Approximate Shipping Weight and Volume

Valve Size	150 ANSI				300 ANSI			
	Shipping Weights		Shipping Volume		Shipping Weights		Shipping Volume	
	lbs	Kgs	Cubic Feet	Cubic Meters	lbs	Kgs	Cubic Feet	Cubic Meters
2"	60	27	1.7	.047	65	29	1.8	.050
3"	105	48	2.4	.067	115	52	2.5	.070
4"	140	64	2.5	.071	165	75	3.1	.087
6"	250	114	4.9	.137	290	132	6.0	.169
8"	400	181	8.9	.253	465	212	10.0	.283

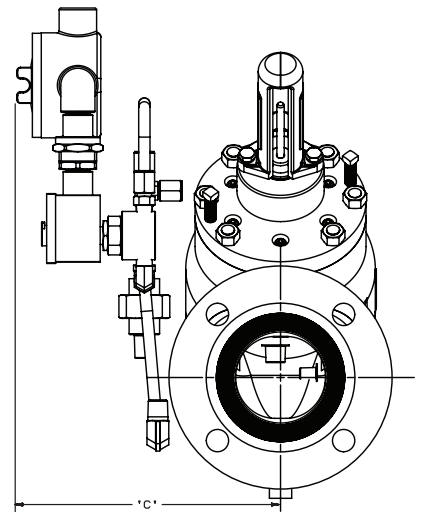
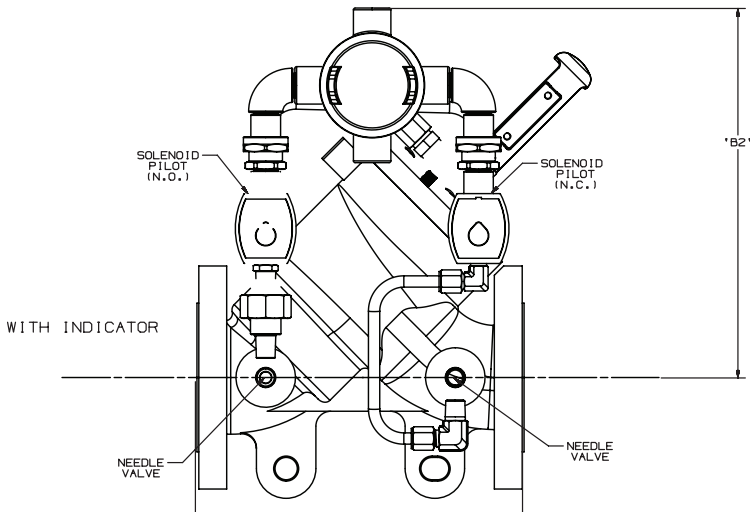
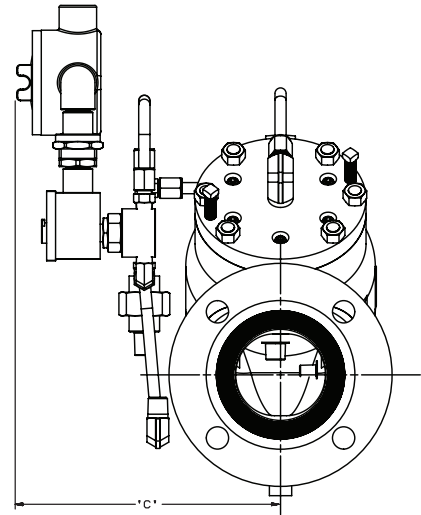
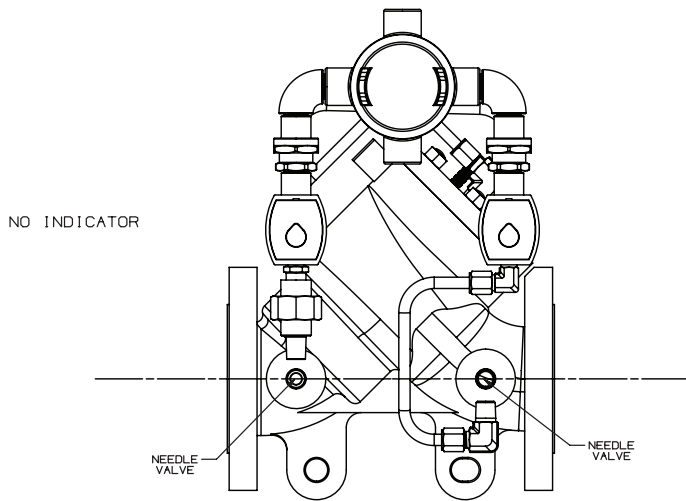

Table 4: Dimensions

Valve Size	ANSI 150				ANSI 300			
	A	B ₁ No Indicator	B ₂ With Indicator	C	A	B ₁ No Indicator	B ₂ With Indicator	C
2"	10.25"	10.25"	11"	8.25"	10.5"	9"	11"	8.25"
	260 mm	229 mm	279 mm	210 mm	267 mm	229 mm	279 mm	210 mm
3"	11"	9"	12"	8.75"	13.125"	9"	12"	8.75"
	279 mm	229 mm	305 mm	222 mm	333 mm	229 mm	305 mm	222 mm
4"	13"	9"	12.5"	9"	14.5"	9"	12.5"	9"
	330 mm	229 mm	318 mm	229 mm	368 mm	229 mm	318 mm	229 mm
6"	17"	12"	15.75"	11"	17.875"	12"	15.75"	11"
	432 mm	305 mm	400 mm	279 mm	454 mm	305 mm	400 mm	279 mm
8"	22.25"	15"	17.5"	11.75"	23.25"	15"	17.5"	11.75"
	565 mm	381 mm	445 mm	298 mm	591 mm	381 mm	445 mm	298 mm

Operational Sequence*

With both solenoids de-energized, the main valve is closed. The main valve can be infinitely positioned anywhere between 0-100% open by digital control of the solenoids. With both solenoids energized, as shown in Figure 2, the valve begins to open. It will only open to the programmed flow rate set in the preset. Normally, the preset is programmed to digitally control low flow startup rate, maximum flow rate, low flow rate before shut-off and final shut-off. The preset will automatically energize and de-energize the solenoids to position the main valve to attain the required flow rate. When the required rates are reached the solenoids will be as shown in Figure 3. This hydraulically locks the main valve piston in position. Should flow increase, the valve will close slightly to adjust to the required rate. All of the positioning is done by digitally controlling the two solenoids as shown in Figures 1, 2 and 3. The valve opening and closing speeds can be adjusted independently via the two needle valves which are shown below.

Figure 1 Closed or Closing Position

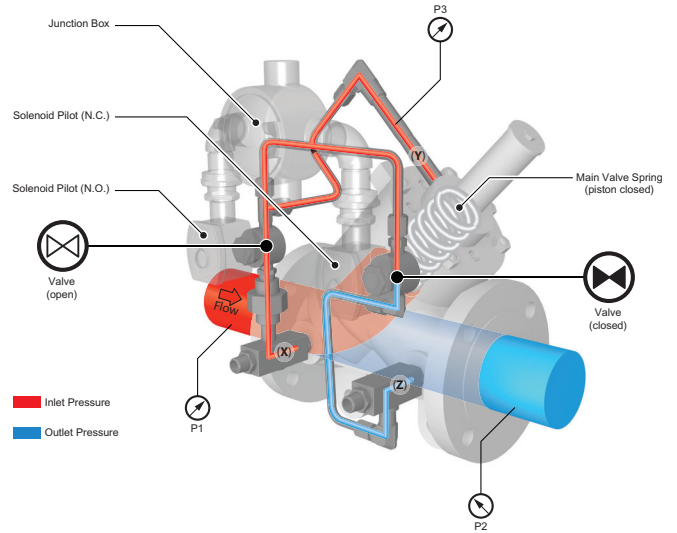

Closed or Closing Position - The normally closed solenoid is closed. The normally open solenoid is open. Y-Port (P3) to Z-port (P2) is closed. X-port (P1) and Y-port (P3) pressures are balanced. The main valve spring, being the differential force, closes the piston and keeps it seated.

Figure 2 Full Open / No Control

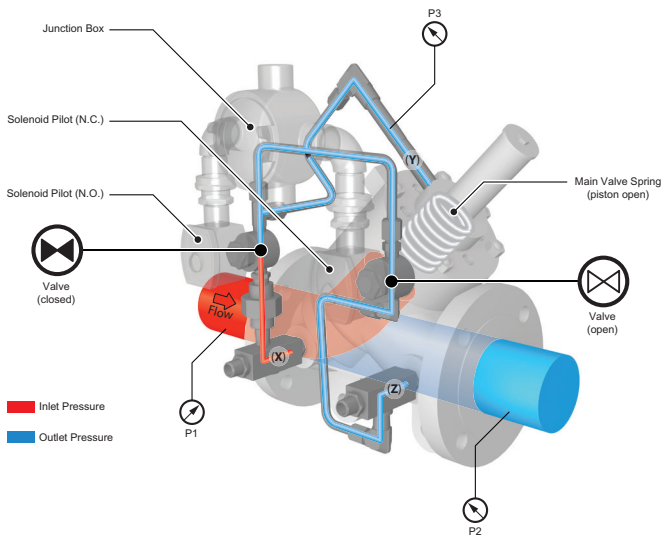

Opening Position - The normally closed solenoid is open. The normally open solenoid is closed. Y-Port (P3) is open to Z-port (P2). X-port (P1) is closed off by the normally open solenoid. The pressure on the bottom of the piston (P1) is greater than the pressure at (P3) plus the spring force; (P1 minus P2) is equal to or greater than the spring force. Therefore, (P1) pressure pushes the piston open.

Figure 3 Controlling Position

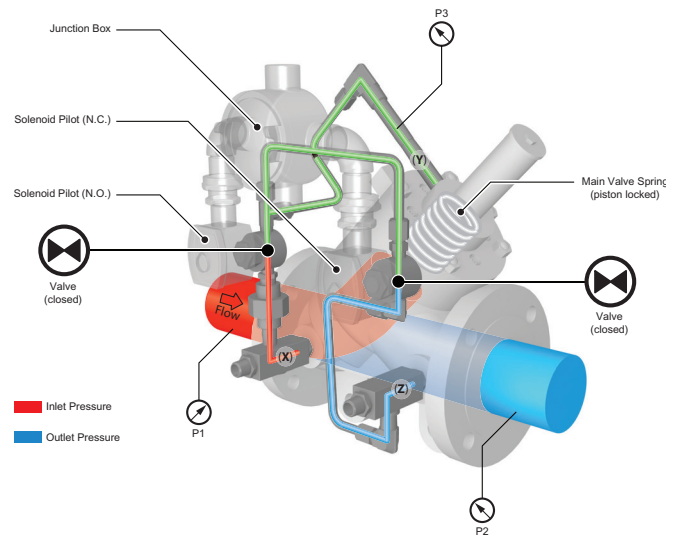

Controlling Position - The normally closed solenoid is closed. The normally open solenoid is closed. Y-Port (P3) to Z-port (P2) is closed. X-port (P1) to Y-port (P3) is closed. Note: The product cannot flow to or from the top of the piston (Y-port). The piston is hydraulically locked in position until the preset commands the valve to open or close as required to maintain the desired flow rate.

*Please refer to the Daniel 788 Digital Control Valve Operating and Maintenance Manual for all operating instructions and safety information.

Typical Applications

The most common application of the Daniel Model 788 Digital Control Valve is for truck loading. The figure below shows the Daniel 788 Digital Control Valve working with turbine meters and electronic preset to precisely control flow rates, batch quantities and blend ratio's of various products being loaded.

Load Rack Installation with Daniel 788 Digital Control Valve for Ratio Blending

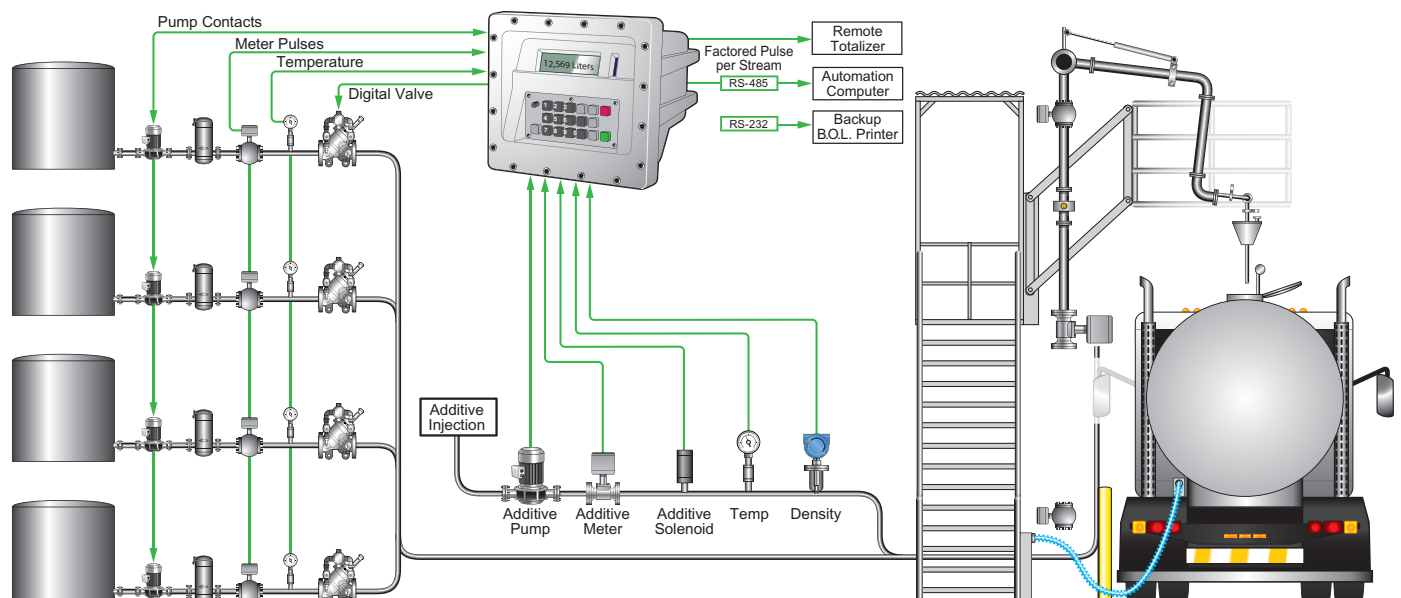

Emerson Automation Solutions

Daniel Measurement and Control, Inc.
North America / Latin America:
Headquarters
USA - Houston, Texas
T +1.713.467.6000
USA Toll Free 1.888.FLOW.001

Middle East, Africa: Dubai, UAE
T +971.4.811.8100
Asia Pacific: Singapore
T +65.6777.8211

www.Emerson.com/Daniel

©2019 Daniel Measurement and Control, Inc. All Rights Reserved. Unauthorized duplication in whole or in part is prohibited. Printed in the USA. DAN-LIQ-DS-788-0220

The Emerson logo is a trademark and service mark of Emerson Electric Co. Daniel Measurement and Control, Inc. ("Daniel") is an Emerson Automation Solutions business unit and a subsidiary of Daniel Industries, Inc. The Daniel name and logo are trademarks of Daniel Industries, Inc. All other trademarks are the property of their respective companies.

DANIEL™

