

Product Data Sheet

PS-001041, Rev. L
April 2013

Micro Motion® ELITE® High Capacity Coriolis Flow and Density Meters

Micro Motion® ELITE® High Capacity Coriolis meters offer unparalleled flow and density measurement performance in a large size meter.

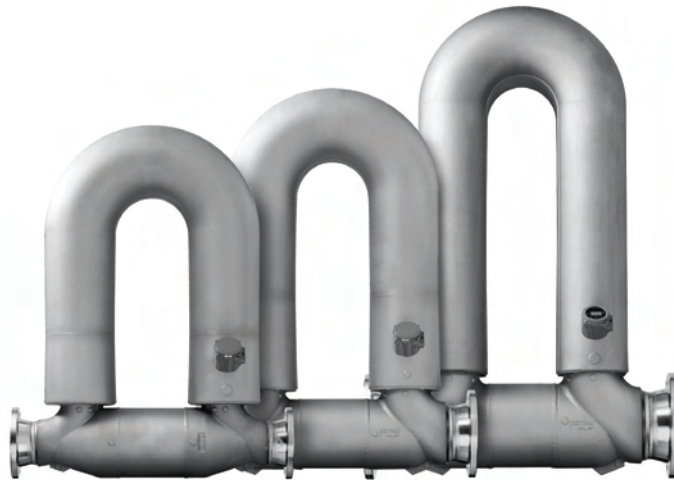

Best precision flow and density measurement in a meter that fits large line sizes

- Model CMFHC4 available with 16-inch process fittings
- Unique design delivers unparalleled measurement sensitivity and stability
- Guarantees consistent, reliable performance over the widest flow range
- Smart Meter Verification for quick, complete meter diagnosis without process interruption

Superior performance in the most challenging applications

- Available in Super Duplex for corrosive or high-pressure applications, ideal for oil production sites with sweet crude and brine
- Industry standard for custody transfer and critical process control
- Best two-phase flow capability for batching, loading, and entrained air applications
- Immune to fluid, process, or environmental effects for superb measurement confidence

ELITE® Peak performance Coriolis meter

ELITE HC Peak performance high capacity meter

F-Series High performance compact drainable Coriolis meter

H-Series Hygienic compact drainable Coriolis meter

T-Series Straight tube full-bore Coriolis meter

R-Series General purpose flow-only Coriolis meter

LF-Series Extreme low-flow Coriolis meter



Micro Motion ELITE High Capacity flow and density meters

Micro Motion Coriolis meters from Emerson Process Management meet a vast range of application needs, ranging from extreme low-flow up to high-flow, high-capacity lines. Cryogenic, hygienic, high-temperature, and high-pressure—Micro Motion meters can handle them all. Micro Motion meters are available with a variety of wetted parts to ensure the best material compatibility.

Coriolis meters. Coriolis meters offer dramatic benefits over traditional volumetric measurement technologies. Coriolis meters:

- Deliver accurate and repeatable process data over a wide range of flow rates and process conditions.
- Provide direct inline measurement of mass flow and density, and also measure volume flow and temperature—all from a single device.
- Have no moving parts, so maintenance costs are minimal.
- Have no requirements for flow conditioning or straight pipe runs, so installation is simplified and less expensive.
- Provide advanced diagnostic tools for both the meter and the process.

ELITE High Capacity Coriolis Meters. Micro Motion® ELITE® High Capacity Meters are the leading meters for precision flow and density measurement, fitting nominal line sizes up to 16 inches (400 mm) (consult factory for details). ELITE meters offer the most accurate measurement available for virtually any process fluid, while exhibiting exceptionally low pressure drop.

ELITE High Capacity meters are available for:

- Standard applications (316L)
- High temperature applications (316L)
- High chloride applications (Super Duplex)
- High pressure applications (Super Duplex)

Now with Smart Meter Verification, Micro Motion ELITE meters deliver industry-best performance:

- Best measurement and ease of use for critical applications
- Best measurement performance for mass, density, and volume, regardless of process or environmental conditions
- Measurement capability for two-phase flow, liquid, and gas custody transfer

Contents

Liquid flow performance	3	Hazardous area classifications	8
Density performance (liquid only)	3	Materials of construction	10
Gas flow performance	4	Weight and center of gravity	10
Environmental effects	4	Dimensions	11
Temperature specifications	5	Fitting options	14
Power consumption	7	Ordering information	17
Pressure ratings	6		

Liquid flow performance

		Mass			Volume ⁽¹⁾			
		lb/min	metric tons/h	kg/h	gal/min	l/h	bbl/hr	m ³ /h
Maximum flow rate	CMFHC2	54,000	1470	1,470,000	6472	1,470,000	12,330	1470
	CMFHC3	94,000	2550	2,550,000	11,227	2,550,000	21,730	2550
	CMFHC4	120,000	3266	3,265,870	14,379	3,265,870	27,830	3266
Mass flow accuracy⁽²⁾		±0.10% of rate ⁽³⁾						
Volume flow accuracy⁽²⁾		±0.10% of rate ⁽³⁾						
Repeatability		±0.05% of rate ⁽³⁾						
		lb/min		kg/h				
Zero stability	CMFHC2	2.5		68				
	CMFHC3	5.0		136				
	CMFHC4	7.5		204				

- (1) Specifications for volumetric flow rate are based on a process-fluid density of 0.998 g/cm³ (998.2 kg/m³). For fluids with density other than 0.998 g/cm³ (998.2 kg/m³), the volumetric flow rate equals the mass flow rate divided by the fluid's density.
- (2) Stated flow accuracy includes the combined effects of repeatability, linearity, and hysteresis. All specifications for liquids are based on reference conditions of water at 68 to 77 °F (20 to 25 °C) and 15 to 30 psig (1 to 2 bar), unless otherwise noted.
- (3) When flow rate is less than zero stability / 0.001, accuracy = ±[(zero stability / flow rate) × 100]% of rate, and repeatability = ±½[(zero stability / flow rate) × 100]%.

Density performance (liquid only)

	g/cm ³	kg/m ³
Accuracy⁽¹⁾	±0.0005	±0.5
Repeatability	±0.0002	±0.2
Range	up to 5	up to 5000

- (1) Accuracy includes the combined effects of repeatability, linearity, and hysteresis. Specifications are based on reference conditions of water at 68 to 77 °F (20 to 25 °C) and 15 to 30 psig (1 to 2 bar), unless otherwise noted.

Gas flow performance

When selecting sensors for gas applications, measurement accuracy is a function of fluid mass flow rate independent of operating temperature, pressure, or composition. However, pressure drop through the sensor is dependent upon operating temperature, pressure, and fluid composition. Therefore, when selecting a sensor for any particular gas application, it is highly recommended that each sensor be sized using Micro Motion's product selector, available at www.micromotion.com.

Mass flow accuracy $\pm 0.35\%$ of rate⁽¹⁾

Repeatability $\pm 0.20\%$ of rate⁽¹⁾

(1) When flow rate is less than zero stability / 0.0035, accuracy equals $\pm[(\text{zero stability} / \text{flow rate}) \times 100]\%$ of rate and repeatability equals $\pm[\frac{1}{2}(\text{zero stability} / \text{flow rate}) \times 100]\%$ of rate.

Environmental effects

Process temperature effect

Process temperature effect is defined as:

- For mass flow measurement, the worst-case zero offset due to process fluid temperature change away from the zeroing temperature.
- For density measurement, the maximum measurement offset due to process fluid temperature change away from the density calibration temperature.

Process temperature effect

	% of maximum flow rate per °C	density accuracy per °C ⁽¹⁾	
		g/cm ³	kg/m ³
CMFHC2	± 0.00025	± 0.000015	± 0.015
CMFHC3	± 0.00025	± 0.000015	± 0.015
CMFHC4	± 0.00025	± 0.000015	± 0.015

Pressure effect

Pressure effect is defined as the change in sensor flow and density sensitivity due to process pressure change away from the calibration pressure.

Pressure effect on mass flow accuracy

	% of rate per psi	% of rate per bar
CMFHC2	-0.0016	-0.023
CMFHC3	-0.0010	-0.015
CMFHC4	-0.0014	-0.020

Pressure effect on density accuracy

	g/cm ³ per psi	kg/m ³ per bar
CMFHC2	-0.0000028	-0.041
CMFHC3	-0.0000025	-0.037
CMFHC4	-0.0000014	-0.021

(1) For -100 °C and above.

Temperature specifications

Accuracy	$\pm 1\text{ }^{\circ}\text{C} \pm 0.5\%$ of reading in $^{\circ}\text{C}$
Repeatability	$\pm 0.2\text{ }^{\circ}\text{C}$
Temperature limits⁽¹⁾⁽²⁾⁽³⁾	Standard temperature (316L and Super Duplex) models

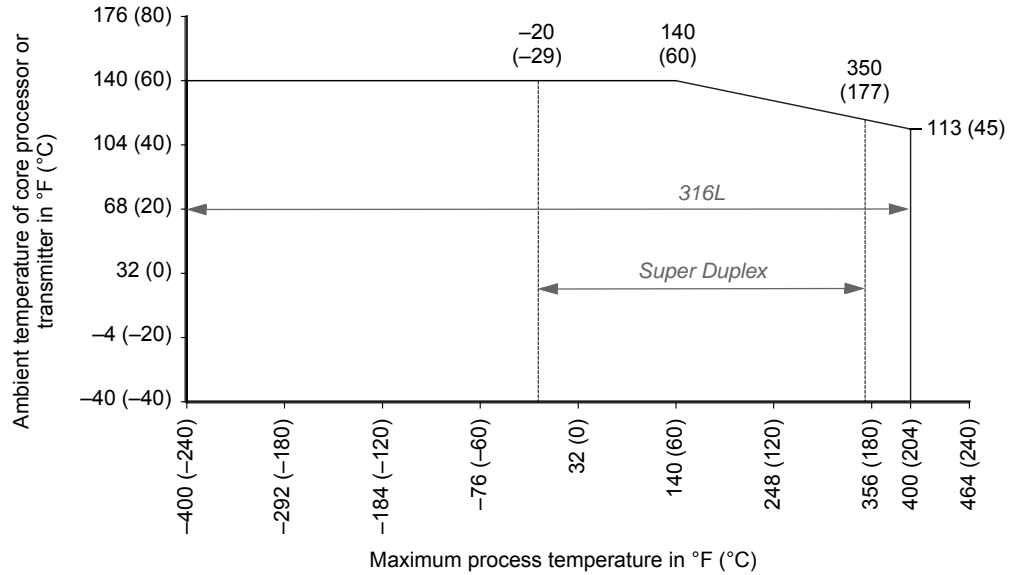

High-temperature (316L) models

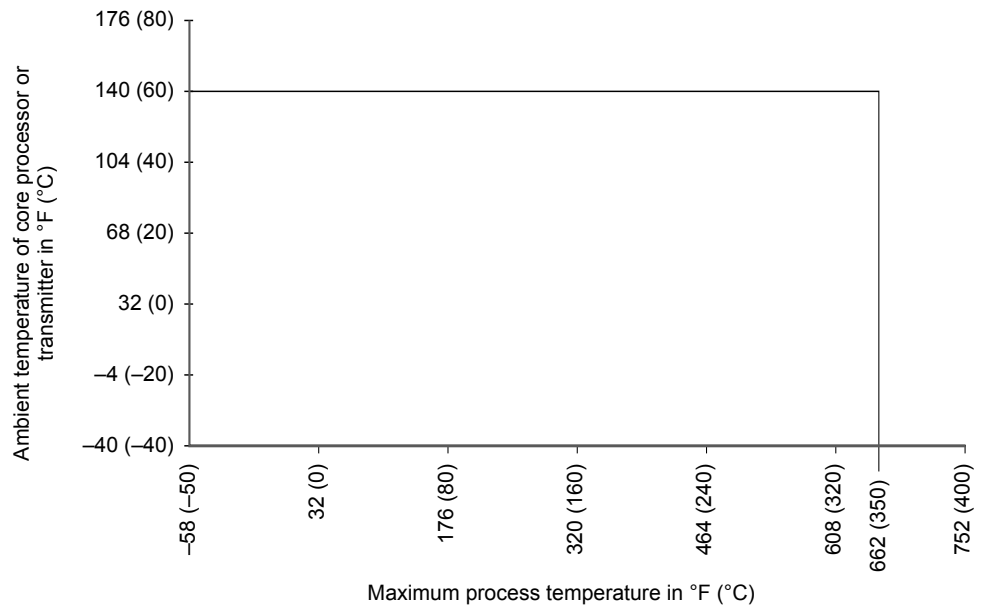

- (1) When ambient temperature is below $-40\text{ }^{\circ}\text{F}$ ($-40\text{ }^{\circ}\text{C}$), a core processor or Model 2400S transmitter must be heated to bring its local ambient temperature to between $-40\text{ }^{\circ}\text{F}$ ($-40\text{ }^{\circ}\text{C}$) and $+140\text{ }^{\circ}\text{F}$ ($+60\text{ }^{\circ}\text{C}$). Long-term storage of electronics at ambient temperatures below $-40\text{ }^{\circ}\text{F}$ ($-40\text{ }^{\circ}\text{C}$) is not recommended.
- (2) Temperature limits may be further restricted by hazardous area approvals. See page 8.
- (3) The extended mount option allows the sensor case to be insulated without covering the transmitter, core processor, or junction box, but does not affect temperature ratings.

Pressure ratings

Pressure ratings are in accordance with ASME B31.3.

Sensor rating ⁽¹⁾		Design pressure	Pressure derating in psi (bar)	
		in psi (bar)	<i>T</i> _{min} : -400 °F (-240 °C)	<i>T</i> _{max} : +400 °F (+204 °C)
CMFHC2M	CMFHC2M	1480 (102)	1480 (102)	1480 (102)
	CMFHC3M	1480 (102)	1480 (102)	1480 (102)
	CMFHC4M	1480 (102)	1480 (102)	1480 (102)
CMFHC2A	CMFHC2A	1480 (102)	1480 (102)	1312 (90)
	CMFHC3A	1480 (102)	1480 (102)	1312 (90)
			<i>T</i> _{min} : -20 °F (-29 °C)	<i>T</i> _{max} : +350 °F (+177 °C)
CMFHC2Y	CMFHC2Y	2320 (160)	2320 (160)	2320 (160)
	CMFHC3Y	2320 (160)	2320 (160)	2320 (160)

PED compliance Sensors comply with council directive 97/23/EC of 29 May 1997 on Pressure Equipment

(1) Process connection rating may differ from sensor rating. The meter will ship from Micro Motion rated to the pressure rating of the sensor or the pressure rating of the process connection, whichever is lower. Please choose process connections accordingly.

Sensor pressure/temperature rating with ASME B16.5 F316/F316L weld neck flanges

Models CMFHC2M through CMFHC4M; Models CMFHC2A and CMFHC3A

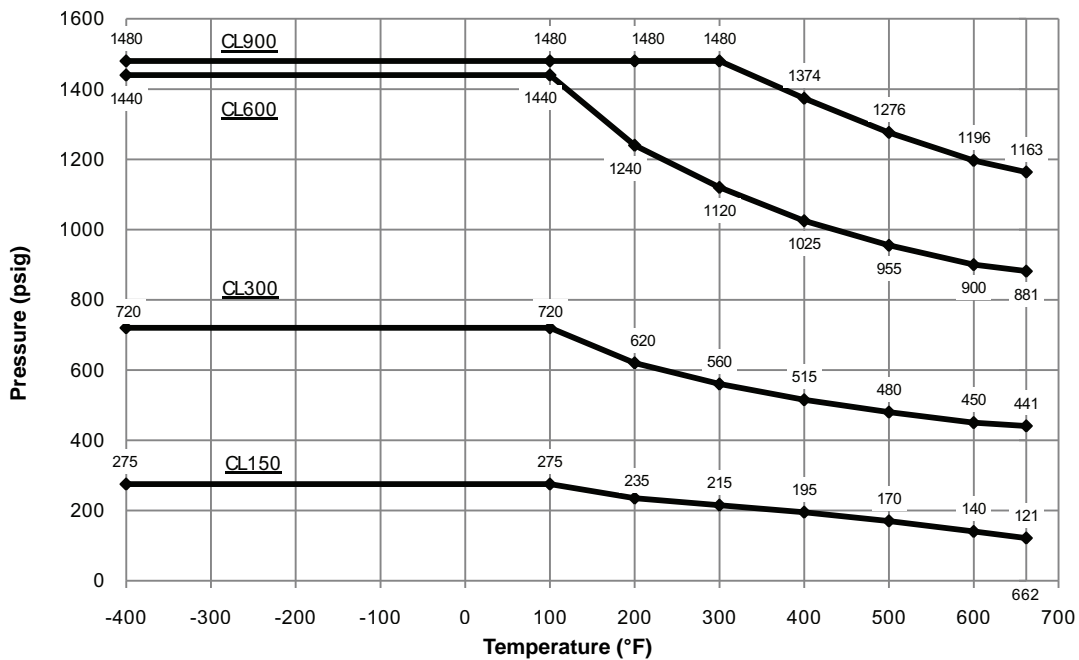

Pressure ratings *continued*

Sensor pressure/temperature ratings with EN1092-1 F316/316L weldneck flanges

Models CMFHC2M through CMFHC4M; Models CMFHC2A and CMFHC3A

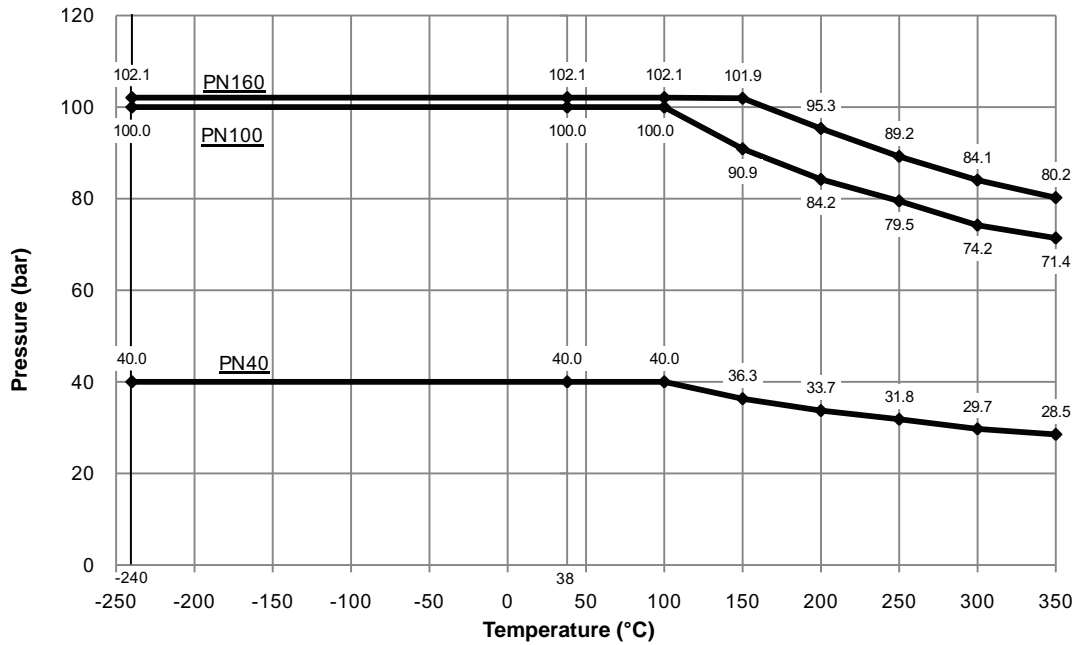

Power consumption

Meter with core processor	4 watts maximum
Meter with Model 2400S transmitter	7 watts maximum
Meter with Model 1700/2700 transmitter	11 watts maximum

Hazardous area classifications

CSA and CSA C-US

Sensor with core processor	Ambient temperature: $-40\text{ }^{\circ}\text{F}$ to $+140\text{ }^{\circ}\text{F}$ ($-40\text{ }^{\circ}\text{C}$ to $+60\text{ }^{\circ}\text{C}$) Class I, Div. 1, Groups C and D Class I, Div. 2, Groups A, B, C and D Class II, Div. 1, Groups E, F, and G
Sensor with Model 2400S transmitter	Ambient temperature: $-40\text{ }^{\circ}\text{F}$ to $+140\text{ }^{\circ}\text{F}$ ($-40\text{ }^{\circ}\text{C}$ to $+60\text{ }^{\circ}\text{C}$) Class I, Div. 2, Groups, A, B, C, and D Class II, Div. 2, Groups F and G

ATEX and IECEx

IECEx	Sensor with core processor	Ex ib IIB/IIC T1–T5 Gb
	Sensor with Model 2400S transmitter	Ex nA IIC T1–T5 Gc
ATEX	Sensor with core processor	CE 0575 Ex II 2G Ex ib IIB/IIC T1–T5 Gb II 2D Ex ib IIIC T ⁽¹⁾ °C Db IP66
	Sensor with Model 2400S transmitter	CE Ex II 3G Ex nA IIC T1–T5 Gc II 3D Ex tc IIIC T ⁽¹⁾ °C Dc IP 66

Standard models (CMFHC2M, CMFHC3M, CMFHC4M) with core processor or Model 2400S transmitter⁽²⁾

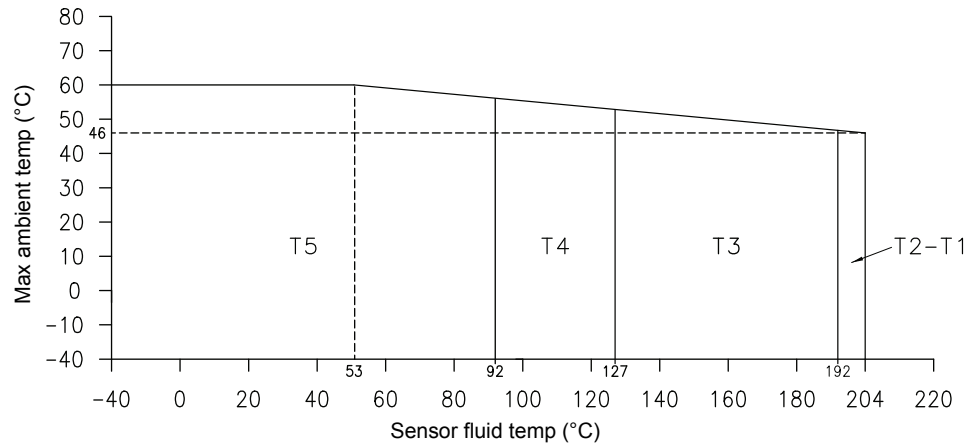

Note 1: Use the temperature graph to determine the temperature class for a given fluid and ambient temperature. The maximum surface temperature T for dust is as follows: T5: $T95\text{ }^{\circ}\text{C}$, T4: $T130\text{ }^{\circ}\text{C}$, T3: $T195\text{ }^{\circ}\text{C}$, T2 to T1: $T207\text{ }^{\circ}\text{C}$.

Ambient temperature range	Ta	$-40\text{ }^{\circ}\text{C}$ to $+60\text{ }^{\circ}\text{C}$
---------------------------	----	--

(1) For ambient and process temperature limits, refer to the temperature graphs.

(2) Maximum ambient temperature for Model 2400S transmitter is $+55\text{ }^{\circ}\text{C}$.

Hazardous area classifications *continued*

ATEX and IECEx

High-temperature models (CMFHC2A and CMFHC3A) with core processor or Model 2400S transmitter⁽¹⁾

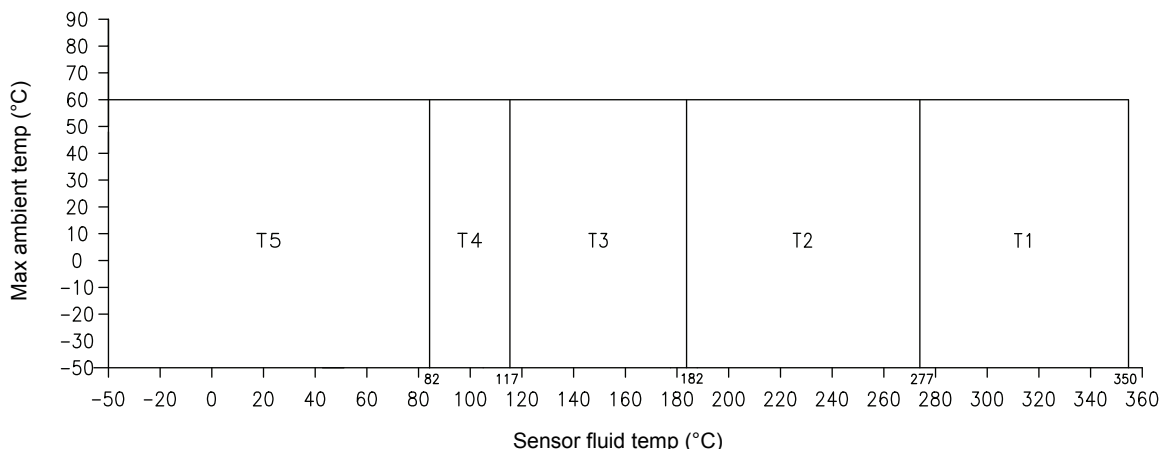

Note 1: Use the temperature graph to determine the temperature class for a given fluid and ambient temperature. The maximum surface temperature T for dust is as follows: T5: T95 °C, T4: T130 °C, T3: T195 °C, T2: T290 °C, T1: T363 °C. The minimum ambient and process fluid temperature allowed for dust is -40 °C.

Ambient temperature range Ta -50 °C to +60 °C

Super Duplex models (CMFHC2Y and CMFHC3Y) with core processor or Model 2400S transmitter⁽¹⁾

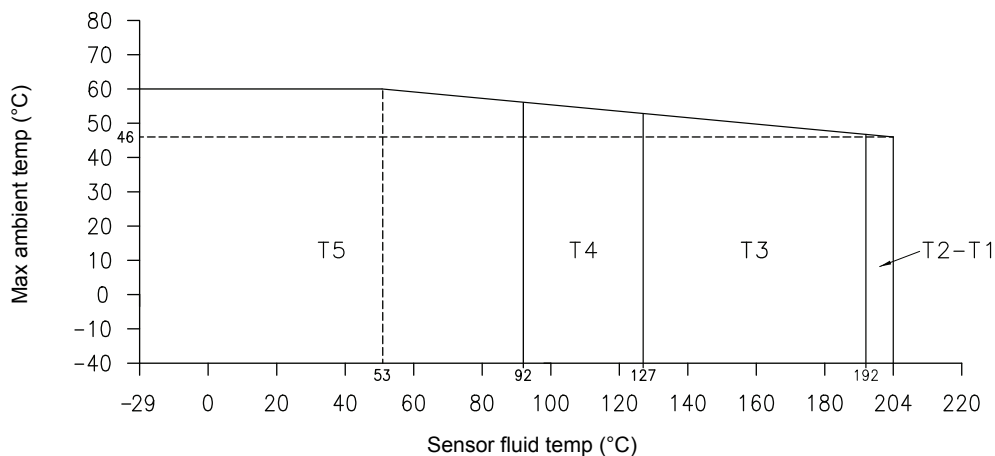

Note 1: Use the temperature graph to determine the temperature class for a given fluid and ambient temperature. The maximum surface temperature T for dust is as follows: T5: T95 °C, T4: T130 °C, T3: T195 °C, T2 to T1: T207 °C. The minimum ambient and process fluid temperature allowed for dust is -40 °C.

Ambient temperature range Ta -40 °C to +60 °C

(1) Maximum ambient temperature for Model 2400S transmitter is +55 °C.

Materials of construction

Wetted parts⁽¹⁾	316L stainless steel or Super Duplex (UNS S32750)
Housing	304L stainless steel ⁽²⁾
Core processor	Polyurethane-painted aluminum or 300-series stainless steel ⁽²⁾ ; NEMA 4X (IP66)
Model 2400S transmitter	Polyurethane-painted aluminum or 300-series stainless steel ⁽²⁾ ; NEMA 4X (IP66)

(1) General corrosion guides do not account for cyclical stress, and therefore should not be relied upon when choosing a wetted material for your Micro Motion sensor. Please refer to the Micro Motion corrosion guide for proper material compatibility information.

(2) 316L stainless steel is available.

Weight and center of gravity

Weight includes the weight of the sensor with CL150 weld neck raised face flanges, plus the weight of the core processor or Model 2400S transmitter.

		lb	kg
Weight	CMFHC2	610	277
	CMFHC3	785	356
	CMFHC4	1331	605

Center of gravity is based on a sensor with integral core processor or Model 2400S transmitter, with meter empty of fluid. Value shown with CL150 flange. Exact center of gravity will vary with the weight of the flange.

		Dim. A (in)	Dim. A (mm)
Center of gravity	CMFHC2	10.9	277
	CMFHC3	14.3	365
	CMFHC4	18.2	605

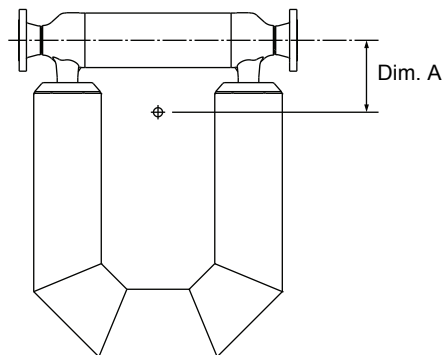

Dimensions

Models CMFHC2M, CMFHC2Y, CMFHC3M, CMFHC3Y, and CMFHC4M

Dimensions in *inches*
(*mm*)

Flow →

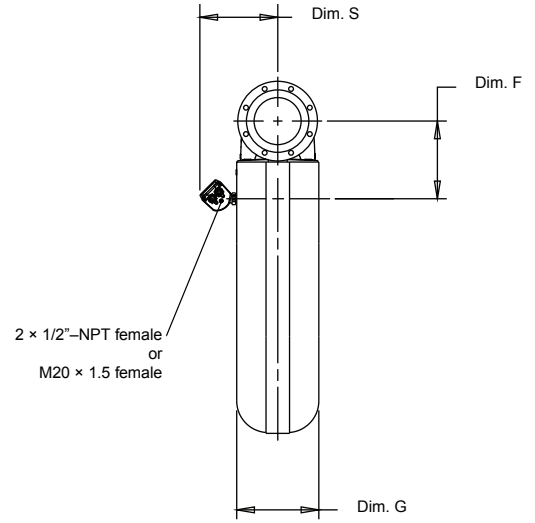
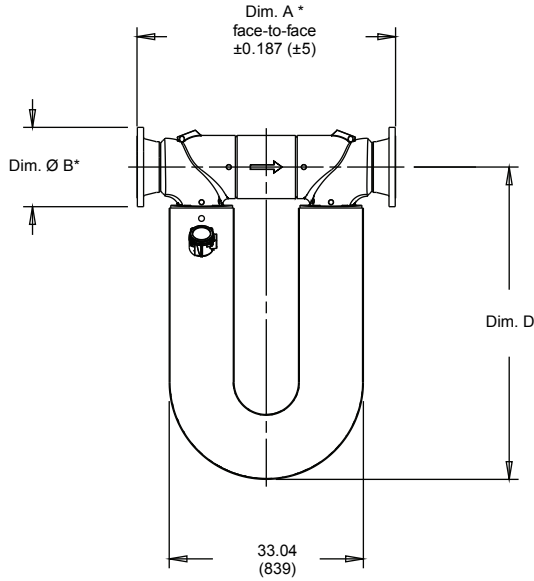

* Note: Dim. A tolerance is ± 0.187 (± 5) for all flanges except fitting codes 451, 452, and 453. For fitting codes 451, 452, and 453 tolerance is ± 0.125 (± 3).

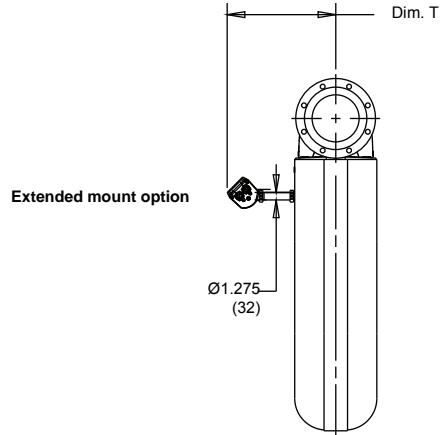

Model	No. of flow tubes	Dimensions in inches (mm) ⁽¹⁾					
		Tube ID	D	F	G	S ⁽²⁾	T ⁽²⁾
CMFHC2	2	3.5 (89)	48.6 (1234)	12.4 (315)	12.8 (325)	12.7 (323)	18.1 (460)
CMFHC3	2	4.5 (114)	53.1 (1349)	13.2 (335)	14.0 (356)	13.3 (338)	18.5 (470)
CMFHC4	2	5.6 (142)	65.5 (1664)	14.1 (358)	17.8 (451)	15.1 (385)	20.5 (521)

(1) For dimensions A and B, see fittings tables on pages 14–16.

(2) Dimensions S and T will vary depending on transmitter/ core processor housing material.

Dimensions *continued*

High-temperature models CMFHC2A and CMFHC3A

Dimensions in *inches*
(*mm*)

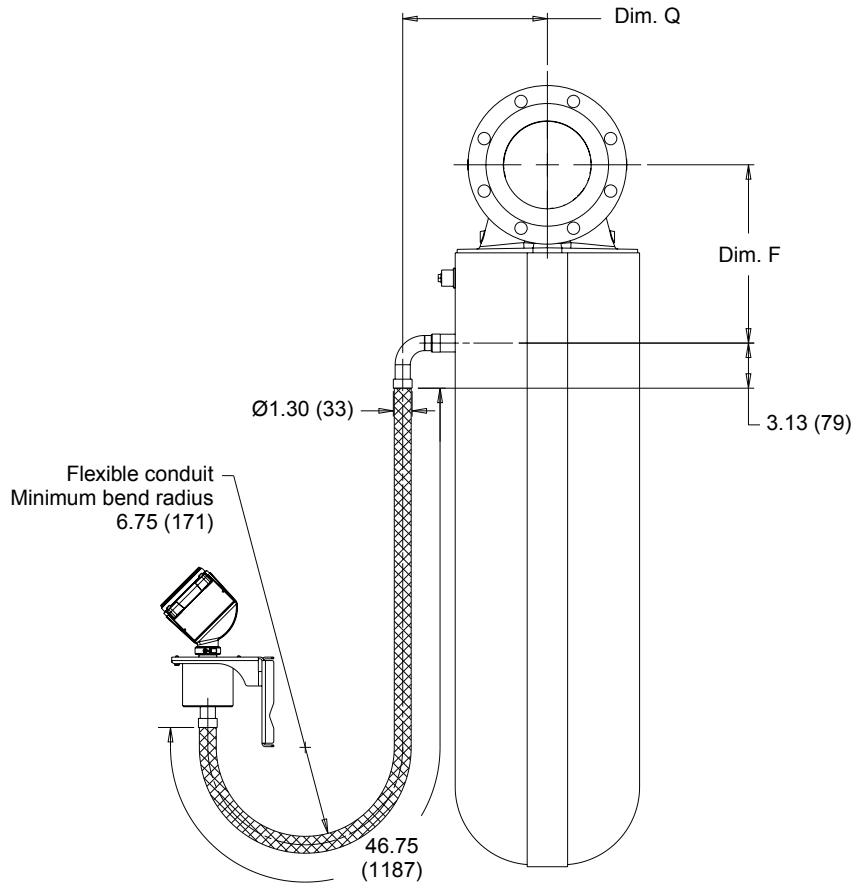

* For additional sensor dimensions, see page 11.

Model	Dimensions in inches (mm)	
	F	Q
CMFHC2A	12.4 (315)	9.0 (228)
CMFHC3A	13.2 (335)	10.2 (258)

Dimensions *continued*

Electronics mounted on high-temperature sensor flexible conduit

Dimensions in *inches*
(*mm*)

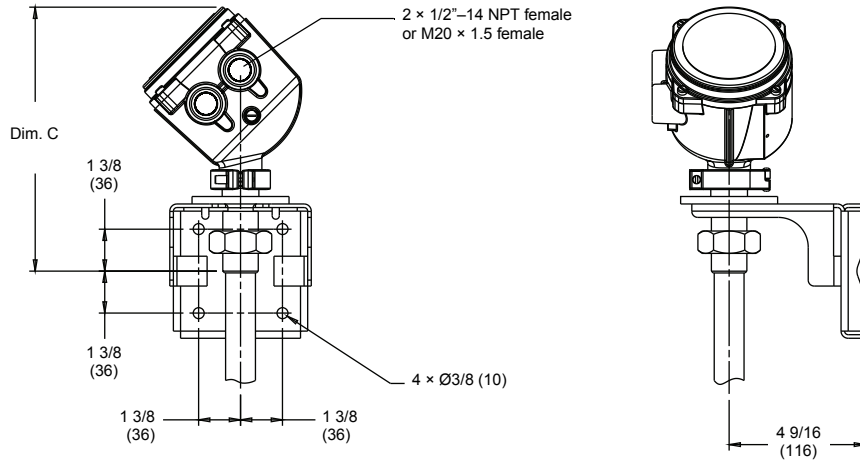

Electronics interface option		Dim. C
0	Model 2400S transmitter, painted aluminum housing	8 7/8 (225)
	Model 2400S transmitter, stainless steel housing	9 1/4 (235)
2	Core processor, painted aluminum housing	8 7/8 (225)
3	Core processor, stainless steel housing	9 1/4 (235)

Fitting options

Fittings listed here are standard options. Other types of fittings are available. The face to face dimensions for any custom fittings ordered using a 998 or 999 fitting code are not represented in this table. It is necessary to confirm face to face dimensions of these fittings at time of ordering. Contact your local Micro Motion representative.

Models CMFHC2M and CMFHC2A

Code	Description						Dim. A ⁽¹⁾	Dim. B
451	ASME B16.5	6-inch	CL150	F316/F316L	Weld neck flange	Raised face	42.81 (1087)	11.00 (279)
452	ASME B16.5	6-inch	CL300	F316/F316L	Weld neck flange	Raised face	43.60 (1107)	12.50 (318)
453	ASME B16.5	6-inch	CL600	F316/F316L	Weld neck flange	Raised face	45.56 (1157)	14.00 (356)
801	EN 1092-1	DN200	PN40	F316/F316L	Weld neck flange	Form B1	42.68 (1084)	14.76 (375)
802	EN 1092-1	DN200	PN100	F316/F316L	Weld neck flange	Form B2	45.99 (1168)	16.93 (430)
803	EN 1092-1	DN200	PN160	F316/F316L	Weld neck flange	Form B2	46.77 (1188)	16.93 (430)
810	ASME B16.5	8-inch	CL150	F316/F316L	Weld neck flange	Raised face	43.75 (1111)	13.50 (343)
811	ASME B16.5	8-inch	CL300	F316/F316L	Weld neck flange	Raised face	44.51 (1131)	15.00 (381)
818	ASME B16.5	8-inch	CL600	F316/F316L	Weld neck flange	Raised face	46.75 (1187)	16.50 (419)
819	ASME B16.5	8-inch	CL900	F316/F316L	Weld neck flange	Raised face	49.01 (1245)	18.50 (470)
821	ASME B16.5	6-inch	CL900	F316/F316L	Weld neck flange	Raised face	47.30 (1201)	15.00 (381)
822	EN 1092-1	DN150	PN40	F316/F316L	Weld neck flange	Form B1	41.71 (1059)	11.81 (300)
823	EN 1092-1	DN150	PN100	F316/F316L	Weld neck flange	Form B2	44.86 (1139)	13.98 (355)
824	EN 1092-1	DN150	PN160	F316/F316L	Weld neck flange	Form B2	45.88 (1165)	13.98 (355)

(1) Tolerance for Dim. A is ± 0.187 in (± 5 mm) for all fittings except codes 451, 452, and 453. For codes 451, 452, and 453 tolerance is ± 0.125 in (± 3 mm).

Model CMFHC2Y

Code	Description						Dim. A ⁽¹⁾	Dim. B
956	EN 1092-1	DN200	PN40	Super duplex	Weld neck flange	Form B1	42.68 (1084)	14.76 (375)
957	EN 1092-1	DN200	PN100	Super duplex	Weld neck flange	Form B2	45.99 (1168)	16.93 (430)
958	EN 1092-1	DN200	PN160	Super duplex	Weld neck flange	Form B2	46.77 (1188)	16.93 (430)
959	EN 1092-1	DN150	PN40	Super duplex	Weld neck flange	Form B1	41.71 (1059)	11.81 (300)
960	EN 1092-1	DN150	PN100	Super duplex	Weld neck flange	Form B2	44.86 (1139)	13.98 (355)
961	EN 1092-1	DN150	PN160	Super duplex	Weld neck flange	Form B2	45.88 (1165)	13.98 (355)
962	ASME B16.5	8-inch	CL150	Super duplex	Weld neck flange	Raised face	43.75 (1111)	13.50 (343)
963	ASME B16.5	8-inch	CL300	Super duplex	Weld neck flange	Raised face	44.51 (1131)	15.00 (381)
964	ASME B16.5	8-inch	CL600	Super duplex	Weld neck flange	Raised face	46.75 (1187)	16.50 (419)
965	ASME B16.5	8-inch	CL900	Super duplex	Weld neck flange	Raised face	49.01 (1245)	18.50 (470)
966	ASME B16.5	6-inch	CL150	Super duplex	Weld neck flange	Raised face	42.81 (1087)	11.00 (279)
967	ASME B16.5	6-inch	CL300	Super duplex	Weld neck flange	Raised face	43.60 (1107)	12.50 (318)
968	ASME B16.5	6-inch	CL600	Super duplex	Weld neck flange	Raised face	45.56 (1157)	14.00 (356)
969	ASME B16.5	6-inch	CL900	Super duplex	Weld neck flange	Raised face	47.30 (1201)	15.00 (381)

(1) Tolerance for Dim. A is ± 0.187 in (± 5 mm).

Fitting options *continued*

Models CMFHC3M and CMFHC3A

Code	Description						Dim. A ⁽¹⁾	Dim. B
801	EN 1092-1	DN200	PN40	F316/F316L	Weld neck flange	Form B1	42.68 (1084)	14.76 (375)
802	EN 1092-1	DN200	PN100	F316/F316L	Weld neck flange	Form B2	45.99 (1168)	16.93 (430)
803	EN 1092-1	DN200	PN160	F316/F316L	Weld neck flange	Form B2	46.77 (1188)	16.93 (430)
804	EN 1092-1	DN250	PN40	F316/F316L	Weld neck flange	Form B1	44.02 (1118)	17.72 (450)
805	EN 1092-1	DN250	PN100	F316/F316L	Weld neck flange	Form B2	48.11 (1222)	19.88 (505)
806	EN 1092-1	DN250	PN160	F316/F316L	Weld neck flange	Form B2	47.95 (1218)	20.28 (515)
810	ASME B16.5	8-inch	CL150	F316/F316L	Weld neck flange	Raised face	43.75 (1111)	13.50 (343)
811	ASME B16.5	8-inch	CL300	F316/F316L	Weld neck flange	Raised face	44.51 (1131)	15.00 (381)
812	ASME B16.5	8-inch	CL600	A105 Carbon Steel	Lap joint flange	316/316L stub	46.75 (1187)	16.50 (419)
813	ASME B16.5	10-inch	CL150	F316/F316L	Weld neck flange	Raised face	43.75 (1111)	16.00 (406)
814	ASME B16.5	10-inch	CL300	F316/F316L	Weld neck flange	Raised face	44.99 (1143)	17.50 (445)
815	ASME B16.5	10-inch	CL600	F316/F316L	Weld neck flange	Raised face	48.25 (1226)	20.00 (508)
816	ASME B16.5	10-inch	CL600	A105 Carbon Steel	Lap joint flange	316/316L stub	49.75 (1264)	20.00 (508)
817	ASME B16.5	10-inch	CL600	F316/F316L	Weld neck flange	Raised face	44.05 (1119)	20.00 (508)
818	ASME B16.5	8-inch	CL600	F316/F316L	Weld neck flange	Raised face	46.75 (1187)	16.50 (419)
819	ASME B16.5	8-inch	CL900	F316/F316L	Weld neck flange	Raised face	49.01 (1245)	18.50 (470)
820	ASME B16.5	10-inch	CL900	F316/F316L	Weld neck flange	Raised face	50.75 (1289)	21.50 (546)

(1) Tolerance for Dim. A is ± 0.187 in (± 5 mm).

Model CMFHC3Y

Code	Description						Dim. A ⁽¹⁾	Dim. B
825	Super duplex	DN200	PN40	EN 1092-1	Weld neck flange	Form B1	42.68 (1084)	14.76 (375)
826	Super duplex	DN200	PN100	EN 1092-1	Weld neck flange	Form B2	45.99 (1168)	16.93 (430)
827	Super duplex	DN200	PN160	EN 1092-1	Weld neck flange	Form B2	46.77 (1188)	16.93 (430)
828	Super duplex	DN250	PN40	EN 1092-1	Weld neck flange	Form B1	44.02 (1118)	17.72 (450)
829	Super duplex	DN250	PN100	EN 1092-1	Weld neck flange	Form B2	48.11 (1222)	19.88 (505)
830	Super duplex	DN250	PN160	EN 1092-1	Weld neck flange	Form B2	47.95 (1218)	20.28 (515)
831	Super duplex	8-inch	CL150	ASME B16.5	Weld neck flange	Raised face	43.75 (1111)	13.50 (343)
832	Super duplex	8-inch	CL300	ASME B16.5	Weld neck flange	Raised face	44.51 (1131)	15.00 (381)
833	Super duplex	8-inch	CL600	ASME B16.5	Weld neck flange	Raised face	46.75 (1187)	16.50 (419)
834	Super duplex	8-inch	CL900	ASME B16.5	Weld neck flange	Raised face	49.01 (1245)	18.50 (470)
836	Super duplex	10-inch	CL150	ASME B16.5	Weld neck flange	Raised face	43.75 (1111)	16.00 (406)
837	Super duplex	10-inch	CL300	ASME B16.5	Weld neck flange	Raised face	44.99 (1143)	17.50 (445)
838	Super duplex	10-inch	CL600	ASME B16.5	Weld neck flange	Raised face	48.25 (1226)	20.00 (508)
839	Super duplex	10-inch	CL900	ASME B16.5	Weld neck flange	Raised face	50.75 (1289)	21.50 (546)

(1) Tolerance for Dim. A is ± 0.187 in (± 5 mm).

Fitting options *continued*

Model CMFHC4M

Code	Description						Dim. A ⁽¹⁾	Dim. B
841	ASME B16.5	10-inch	CL150	F316/F316L	Weld neck flange	Raised face	47.75 (1213)	16.00 (406)
842	ASME B16.5	10-inch	CL300	F316/F316L	Weld neck flange	Raised face	48.99 (1244)	17.50 (445)
843	ASME B16.5	10-inch	CL600	F316/F316L	Weld neck flange	Raised face	52.25 (1327)	20.00 (508)
844	ASME B16.5	10-inch	CL900	F316/F316L	Weld neck flange	Raised face	54.75 (1391)	21.50 (546)
845	ASME B16.5	12-inch	CL150	F316/F316L	Weld neck flange	Raised face	48.75 (1238)	19.00 (483)
846	ASME B16.5	12-inch	CL300	F316/F316L	Weld neck flange	Raised face	49.99 (1270)	20.50 (521)
847	ASME B16.5	12-inch	CL600	F316/F316L	Weld neck flange	Raised face	52.49 (1333)	22.00 (559)
848	ASME B16.5	12-inch	CL900	F316/F316L	Weld neck flange	Raised face	56.01 (1423)	24.00 (610)
849	EN 1092-1	DN250	PN40	F316/F316L	Weld neck flange	Form B1	48.02 (1220)	17.72 (450)
850	EN 1092-1	DN250	PN100	F316/F316L	Weld neck flange	Form B2	52.11 (1324)	19.88 (505)
851	EN 1092-1	DN250	PN160	F316/F316L	Weld neck flange	Form B2	51.95 (1320)	20.28 (515)
852	EN 1092-1	DN300	PN40	F316/F316L	Weld neck flange	Form B1	48.81 (1240)	20.28 (515)
853	EN 1092-1	DN300	PN100	F316/F316L	Weld neck flange	Form B2	53.14 (1350)	23.03 (585)
854	EN 1092-1	DN300	PN160	F316/F316L	Weld neck flange	Form B2	53.53 (1360)	23.03 (585)
855	ASME B16.5	16-inch	CL150	F316/F316L	Weld neck flange	Raised face	Consult factory	Consult factory
856	ASME B16.5	16-inch	CL300	F316/F316L	Weld neck flange	Raised face	Consult factory	Consult factory
857	ASME B16.5	16-inch	CL600	F316/F316L	Weld neck flange	Raised face	Consult factory	Consult factory

(1) Tolerance for Dim. A is ± 0.187 in (± 5 mm).

Ordering information

Standard models

Model	Product description
CMFHC2M	Micro Motion Coriolis ELITE sensor; 6 to 8-inch (150 to 200 mm); 316L stainless steel
CMFHC3M	Micro Motion Coriolis ELITE sensor; 8 to 10-inch (200 to 250 mm); 316L stainless steel
CMFHC4M	Micro Motion Coriolis ELITE sensor; 10 to 16-inch (250 to 400 mm); 316L stainless steel
Code	Process connections
###	See process fitting options on pages 14–16.
Code	Case options
N	Standard pressure containment
Code	Electronics interface
0	Model 2400S transmitter
1	Extended mount Model 2400S transmitter
2	4-wire polyurethane-painted aluminum integral core processor for remote mount transmitters
3	4-wire stainless steel integral core processor for remote mount transmitters
4	4-wire polyurethane-painted aluminum integral extended mount core processor for remote mount transmitters
5	4-wire stainless steel integral extended mount core processor for remote mount transmitters
Code	Conduit connections
	Electronics interface codes 0 and 1
A	No gland
	Electronics interface codes 2, 3, 4, and 5
B	1/2-inch NPT — no gland
E	M20 — no gland
F	Brass/nickel cable gland (cable diameter 0.335 to 0.394 inches [8.5 to 10 mm])
G	Stainless steel cable gland (cable diameter 0.335 to 0.394 inches [8.5 to 10 mm])
Code	Approvals
	Electronics interface codes 0 and 1
M	Micro Motion Standard (no approval)
N	Micro Motion Standard / PED compliant
2	CSA Class I, Div. 2
V	ATEX Equipment Category 3 (Zone 2) / PED compliant
3	IECEX Zone 2
	Electronics interface codes 2, 3, 4, and 5
M	Micro Motion Standard (no approval)
N	Micro Motion Standard / PED compliant
A	CSA C-US (U.S.A. and Canada)
Z	ATEX Equipment Category 2 (Zone 1) / PED compliant
6	ATEX Equipment Category 2 (Zone 1 – IIC modified) / PED compliant
I	IECEX Zone 1
7	IECEX Zone 1 – IIC modified
Continued on next page	

Ordering information *continued*

Standard models *continued*

Code	Language
A	Danish CE requirements document and English installation manual
D	Dutch CE requirements document and English installation manual
E	English installation manual
F	French installation manual
G	German installation manual
H	Finnish CE requirements document and English installation manual
I	Italian installation manual
J	Japanese installation manual
M	Chinese installation manual
N	Norwegian CE requirements document and English installation manual
O	Polish installation manual
P	Portuguese installation manual
S	Spanish installation manual
W	Swedish CE requirements document and English installation manual
C	Czech installation manual
B	Hungarian CE requirements document and English installation manual
K	Slovak CE requirements document and English installation manual
T	Estonian CE requirements document and English installation manual
U	Greek CE requirements document and English installation manual
L	Latvian CE requirements document and English installation manual
V	Lithuanian CE requirements document and English installation manual
Y	Slovenian CE requirements document and English installation manual
Code	Calibration options
Z	0.10% mass flow and 0.0005 g/cm ³ (0.5 kg/m ³) density
Code	Measurement application software
Z	No measurement application software
Code	Factory options
Z	Standard product
X	ETO product

Ordering information *continued*

Super Duplex models

Model	Product description
CMFHC2Y	Micro Motion Coriolis ELITE sensor; 6 to 8-inch (150 to 200 mm); Super Duplex
CMFHC3Y	Micro Motion Coriolis ELITE sensor; 8 to 10-inch (200 to 250 mm); Super Duplex
Code	Process connections
###	See process fitting options on pages 14–16.
Code	Case options
N	Standard pressure containment
Code	Electronics interface
0	Model 2400S transmitter
1	Extended mount Model 2400S transmitter
2	4-wire polyurethane-painted aluminum integral core processor for remote mount transmitters
3	4-wire stainless steel integral core processor for remote mount transmitters
4	4-wire polyurethane-painted aluminum integral extended mount core processor for remote mount transmitters
5	4-wire stainless steel integral extended mount core processor for remote mount transmitters
Code	Conduit connections
	Electronics interface codes 0 and 1
A	No gland
	Electronics interface codes 2, 3, 4, and 5
B	1/2-inch NPT — no gland
E	M20 — no gland
F	Brass/nickel cable gland (cable diameter 0.335 to 0.394 inches [8.5 to 10 mm])
G	Stainless steel cable gland (cable diameter 0.335 to 0.394 inches [8.5 to 10 mm])
Code	Approvals
	Electronics interface codes 0 and 1
M	Micro Motion Standard (no approval)
N	Micro Motion Standard / PED compliant
2	CSA Class I, Div. 2
V	ATEX Equipment Category 3 (Zone 2) / PED compliant
3	IECEX Zone 2
	Electronics interface codes 2, 3, 4, and 5
M	Micro Motion Standard (no approval)
N	Micro Motion Standard / PED compliant
A	CSA C-US (U.S.A. and Canada)
Z	ATEX Equipment Category 2 (Zone 1) / PED compliant
I	IECEX Zone 1
6	ATEX Equipment Category 2 (Zone 1 – IIC modified) / PED compliant
7	IECEX Zone 1 – IIC modified
Continued on next page	

Ordering information *continued*

Super Duplex models *continued*

Code	Language
A	Danish CE requirements document and English installation manual
D	Dutch CE requirements document and English installation manual
E	English installation manual
F	French installation manual
G	German installation manual
H	Finnish CE requirements document and English installation manual
I	Italian installation manual
J	Japanese installation manual
M	Chinese installation manual
N	Norwegian CE requirements document and English installation manual
O	Polish installation manual
P	Portuguese installation manual
S	Spanish installation manual
W	Swedish CE requirements document and English installation manual
C	Czech installation manual
B	Hungarian CE requirements document and English installation manual
K	Slovak CE requirements document and English installation manual
T	Estonian CE requirements document and English installation manual
U	Greek CE requirements document and English installation manual
L	Latvian CE requirements document and English installation manual
V	Lithuanian CE requirements document and English installation manual
Y	Slovenian CE requirements document and English installation manual
Code	Calibration options
Z	0.10% mass flow and 0.0005 g/cm ³ (0.5 kg/m ³) density
Code	Measurement application software
Z	No measurement application software
Code	Factory options
Z	Standard product
X	ETO product

Ordering information *continued*

High-temperature models

Model	Product description
CMFHC2A	Micro Motion Coriolis ELITE sensor; 6 to 8-inch (150 to 200 mm); high temperature; 316L stainless steel
CMFHC3A	Micro Motion Coriolis ELITE sensor; 8 to 10-inch (200 to 250 mm); high temperature; 316L stainless steel
Code	Process connections
###	See process fitting options on pages 14–16.
Code	Case options
N	Standard pressure containment
Code	Electronics interface
0	Model 2400S transmitter
2	4-wire polyurethane-painted aluminum integral core processor for remote mount transmitters
3	4-wire stainless steel integral core processor for remote mount transmitters
Code	Conduit connections
	Electronics interface code 0
A	No gland
	Electronics interface codes 2 and 3
B	1/2-inch NPT — no gland
E	M20 — no gland
F	Brass/nickel cable gland (cable diameter 0.335 to 0.394 inches [8.5 to 10 mm])
G	Stainless steel cable gland (cable diameter 0.335 to 0.394 inches [8.5 to 10 mm])
Code	Approvals
	Electronics interface code 0
M	Micro Motion Standard (no approval)
N	Micro Motion Standard / PED compliant
2	CSA Class I, Div. 2
V	ATEX Equipment Category 3 (Zone 2) / PED compliant
3	IECEx Zone 2
	Electronics interface codes 2 and 3
M	Micro Motion Standard (no approval)
N	Micro Motion Standard / PED compliant
A	CSA C-US (U.S.A. and Canada)
Z	ATEX Equipment Category 2 (Zone 1) / PED compliant
6	ATEX Equipment Category 2 (Zone 1 – IIC modified) / PED compliant
1	IECEx Zone 1
7	IECEx Zone 1 – IIC modified
Continued on next page	

Ordering information *continued*

High-temperature models *continued*

Code	Language
A	Danish CE requirements document and English installation manual
D	Dutch CE requirements document and English installation manual
E	English installation manual
F	French installation manual
G	German installation manual
H	Finnish CE requirements document and English installation manual
I	Italian installation manual
J	Japanese installation manual
M	Chinese installation manual
N	Norwegian CE requirements document and English installation manual
O	Polish installation manual
P	Portuguese installation manual
S	Spanish installation manual
W	Swedish CE requirements document and English installation manual
C	Czech installation manual
B	Hungarian CE requirements document and English installation manual
K	Slovak CE requirements document and English installation manual
T	Estonian CE requirements document and English installation manual
U	Greek CE requirements document and English installation manual
L	Latvian CE requirements document and English installation manual
V	Lithuanian CE requirements document and English installation manual
Y	Slovenian CE requirements document and English installation manual
Code	Calibration options
Z	0.10% mass flow and 0.0005 g/cm ³ (0.5 kg/m ³) density
Code	Measurement application software
Z	No measurement application software
Code	Factory options
Z	Standard product
X	ETO product

Micro Motion—The undisputed leader in flow and density measurement



World-leading Micro Motion measurement solutions from Emerson Process Management deliver what you need most:

Technology leadership

Micro Motion introduced the first reliable Coriolis meter in 1977. Since that time, our ongoing product development has enabled us to provide the highest performing measurement devices available.

Product breadth

From compact, drainable process control to high flow rate fiscal transfer—look no further than Micro Motion for the widest range of measurement solutions.

Unparalleled value

Benefit from expert phone, field, and application service and support made possible by more than 750,000 meters installed worldwide and over 30 years of flow and density measurement experience.

 www.micromotion.com

© 2013 Micro Motion, Inc. All rights reserved.

The Emerson logo is a trademark and service mark of Emerson Electric Co. Micro Motion, ELITE, ProLink, MVD and MVD Direct Connect are marks of one of the Emerson Process Management family of companies. All other trademarks are property of their respective owners.

Micro Motion supplies this publication for informational purposes only. While every effort has been made to ensure accuracy, this publication is not intended to make performance claims or process recommendations. Micro Motion does not warrant, guarantee, or assume any legal liability for the accuracy, completeness, timeliness, reliability, or usefulness of any information, product, or process described herein. We reserve the right to modify or improve the designs or specifications of our products at any time without notice. For actual product information and recommendations, please contact your local Micro Motion representative.

Emerson Process Management Micro Motion Americas

Worldwide Headquarters
7070 Winchester Circle
Boulder, Colorado USA 80301
T: +1 800 522 6277
T: +1 (303) 527 5200
F: +1 (303) 530 8459
Mexico T: 52 55 5809 5300
Argentina T: 54 11 4837 7000
Brazil T: 55 15 3238 3527
Venezuela T: 58 26 1792 1858

Emerson Process Management Micro Motion Europe/Middle East

Central & Eastern Europe T: +41 41 7686 111
Dubai T: +971 4 811 8100
Abu-Dahbi T: +971 2 697 2000
France T: 0800 917 901
Germany T: 0800 182 5347
Italy T: 8008 77334
The Netherlands T: +31 318 495 555
Belgium T: +32 2 716 77 11
Spain T: +34 913 586 000
U.K. T: 0870 240 1978
Russia/CIS T: +7 495 981 9811

Emerson Process Management Micro Motion Asia Pacific

Australia T: (61) 3 9721 0200
China T: (86) 21 2892 9000
India T: (91) 22 6662 0566
Japan T: (81) 3 5769 6803
South Korea T: (82) 2 3438 4600
Singapore T: (65) 6 777 8211

For a complete list of contact information and web sites, please visit: www.emersonprocess.com/home/contacts/global

